

# Vinyl Siding Installation



## A How-To Guide



This guide is published by the Vinyl Siding Institute (VSI), a business unit of The Society of the Plastics Industry, Inc. (SPI), as a service to the industry. VSI represents producers of vinyl siding and suppliers to the vinyl siding industry. The information provided in this publication is offered in good faith and believed to be reliable, but is made without warranty, express or implied, as to merchantability, fitness for a particular purpose, or any other matter. SPI and VSI do not endorse the proprietary products or processes of any manufacturer.

This publication is not intended to provide specific advice, legal or otherwise, on particular products or processes. Readers should consult with their own legal and technical advisors, vinyl siding suppliers, and other appropriate sources (including but not limited to product or package labels, technical bulletins, or sales literature) that contain information about known and reasonably foreseeable health and safety risks of their proprietary products and processes. SPI, its members, and contributors do not assume any responsibility for the users' compliance with applicable laws and regulations, nor for any persons relying on the information contained in this guide.

Information about individual manufacturers' products contained herein has been provided by those manufacturers, who are solely responsible for the accuracy and completeness of the data.

### **Use of Manufacturers' Instructions**

Some specialized products may require unique installation instructions. Please contact the manufacturer directly for information about installing those products.

For general information about vinyl siding products, contact the Vinyl Siding Institute at:



1801 K Street, NW, Suite 600K  
Washington, DC 20006-1301

Web address: [www.vinylsiding.org](http://www.vinylsiding.org)

Vinyl Siding Information Center (VSIC): 1-888-FOR-VSI-1 (1-888-367-8741)

# CONTENTS

<b>Foreword</b> .....	<b>1</b>
<b>Important Notes</b> .....	<b>2</b>
Fire Safety Information .....	2
Storage and Transportation.....	2
Basic Installation Rules .....	3
Cleanup .....	4
Disposal.....	5
<b>Terms to Know</b> .....	<b>6</b>
<b>Materials, Tools, and Accessories</b> .....	<b>8</b>
Basic Installation Tools and Equipment.....	8
Special Tools .....	9
Accessories .....	9
<b>Getting Started</b> .....	<b>10</b>
How to Measure .....	10
Estimating Required Materials .....	10
Estimating Worksheet .....	12
Fastener Choices .....	13
Fastening Procedure .....	14
Cutting the Siding .....	15
Preparing the Walls .....	16
New Construction .....	16
Residing.....	16
<b>Installing Accessories</b> .....	<b>17</b>
Starter Strip .....	17
Outside and Inside Corner Posts .....	18
Windows, Doors, and Roof Lines .....	19
Gable and Trim .....	21
<b>Horizontal Siding Installation</b> .....	<b>22</b>
Installing Panels .....	22
Fitting Siding Around Fixtures .....	23
Fitting Under Windows .....	23
Sidewall Flashing at Roof Lines .....	24
Finishing at the Top .....	25
Transition from Horizontal to Vertical .....	26
Transition from Brick to Vinyl Siding .....	26

## CONTENTS (CONT.)

<b>Vertical Siding and Accessories Installation</b> .....	<b>27</b>
Preparation.....	27
Accessories .....	27
Installing Outside and Inside Corner Posts .....	27
Bottom Receiver .....	28
Window, Door, and Roof Trim .....	28
Sidewalls .....	29
Starter Strip .....	29
Panels.....	30
Optional Method for Gable End Sidewalls .....	30
Windows and Doors .....	30
Corners.....	30
Gable Ends.....	31
<b>Soffit Installation</b> .....	<b>32</b>
Preparation.....	32
Installation Over Open Eaves .....	33
Installation Over Enclosed Eaves .....	35
Porch Ceilings .....	36
New Construction Projects .....	36
Residing Projects .....	37
<b>Other Recommendations</b> .....	<b>37</b>
Replacing a Damaged Panel .....	37
Residing Over Asbestos Siding .....	38
Capping a Corner Post .....	38
Repairing a Damaged Corner Post .....	38
Historic Restoration .....	39

## FOREWORD

Known for its outstanding performance qualities, vinyl siding is increasingly the material of choice for homeowners, remodeling contractors, architects, and builders. Compared to other siding products, vinyl is attractive, durable, easy to maintain, and cost-effective. Siding is available in a variety of textures, ranging from matte surfaces to deeply embossed wood grain surfaces, which simulate wood clapboard siding.

For best results, it is recommended that vinyl siding meet the requirements of the *American Society for Testing and Materials (ASTM) D3679–Standard Specification for Rigid Vinyl Siding*. As a service to the industry, the Vinyl Siding Institute (VSI) sponsors a program that allows manufacturers to certify, with independent, third-party verification, that their siding meets or exceeds this specification. For a listing of certified products, see VSI's Web site at [www.vinylsiding.org](http://www.vinylsiding.org) or call the Vinyl Siding Information Center at 1-888-FOR-VSI-1 (1-888-367-8741). In addition, look for the certification label on boxes of siding (Fig. 1).



Figure 1.

This manual sets forth the basic guidelines for vinyl siding installation. The instructions herein are based, in part, on *ASTM Specification D4756*, the standard method for installation of vinyl siding and soffit. Updated information has been added as necessary. **Additionally, it is recommended that installers review local building codes and manufacturers' literature for variations that may apply to specific products or geographic areas.**

The method of applying vinyl siding and soffit is essentially the same for new construction and residing. However, where required, special instructions for new construction and residing are included, as well as recommendations for historic restoration. In all applications, care should be exercised to properly prepare the structure. See the “Basic Installation Rules” and additional details throughout this document for proper installation techniques.

# IMPORTANT NOTES

## Fire Safety Information

Exterior vinyl building materials require little maintenance for many years. Nevertheless, common sense dictates that builders and suppliers of vinyl products store, handle, and install vinyl materials in a manner that avoids damage to the product and/or the structure. Owners and installers should take a few simple steps to protect vinyl building materials from fire.

**To Home and Building Owners:** Rigid vinyl siding is made from organic materials and will melt or burn when exposed to a significant source of flame or heat. Building owners, occupants, and outside maintenance personnel should always take normal precautions to keep sources of fire, such as grills, and combustible materials, such as dry leaves, mulch, and trash, away from vinyl siding.

**To the Building Trades, Specifiers, Professionals, and to Do-It-Yourself Installers:** When rigid vinyl siding is exposed to significant heat or flame, the vinyl will soften, sag, melt, or burn, and may thereby expose material underneath. Care must be exercised when selecting underlayment materials because many underlayment materials are made from organic materials that are combustible. It is important to ascertain the fire properties of underlayment materials prior to installation. **All building materials should be installed in accordance with local, state, and federal building code and fire regulations.**

## Storage and Transportation

When transporting vinyl siding to a job site, make certain to keep the cartons flat and supported along their entire length. At the job site, take the following precautions when storing panels:

- Store the cartons on a flat surface and support the entire length of the cartons.
- Keep the cartons dry.
- Store the cartons away from areas where falling objects or other construction activity may cause damage.
- Do not store the cartons in stacks more than 12 boxes high.
- Do not store the cartons in any location where temperatures may exceed 130°F (e.g., on blacktop pavement during unusually hot weather or under dark tarps or plastic wraps without air circulation).

## BASIC INSTALLATION RULES

Before getting started, it is important to review several rules of thumb for vinyl siding application. The following rules, which come up throughout this guide, are critical for proper vinyl siding installation:

1. Installed panels must move freely from side to side.
2. When installing a siding panel, push up from the bottom until the lock is fully engaged with the piece below it. Without stretching the panel, reach up and nail it into place.
3. Fasten nails or other fasteners in the center of the nailing slot.
4. Do not force the panels up or down when fastening in position.
5. Do not drive the head of the nail tightly against the siding nail hem. Allow 1/32" (about the thickness of a dime) clearance between the fastener head and the siding panel. Drive nails straight and level to prevent distortion and buckling of the panel.
6. Leave a minimum of 1/4" clearance at all openings and stops to allow for normal expansion and contraction. When installing in temperatures below 40°F, increase minimum clearance to 3/8".
7. Do not caulk the panels where they meet the receiver of inside corners, outside corners, or J-trim. Do not caulk the overlap joints.
8. Do not face-nail or staple through siding. Vinyl siding expands and contracts with outside temperature changes. Face-nailing can result in ripples in the siding.
9. In residing, furring or removal of uneven original siding may be necessary.
10. In new construction, avoid the use of green lumber as the underlayment. Keep in mind that siding can only be as straight and stable as what lies under it.



## Cleanup

The beauty of vinyl siding is maintained with little effort. Although vinyl siding will get dirty, like anything exposed to the atmosphere, a heavy rain will do wonders in cleaning it. Or, it's possible to wash it down with an ordinary garden hose. If neither rain nor hosing does a satisfactory job, follow these simple instructions:

1. Use an ordinary, long-handled car washing brush. This brush has soft bristles, and the handle fastens onto the end of the hose. It allows the siding to be washed just like a car. Avoid using stiff bristle brushes or abrasive cleaners, which may change the gloss of the cleaned area and cause the siding to look splotchy.
2. To remove soot and grime found in industrial areas, wipe down the siding with a solution made up of the following:
  - 1/3 cup powdered detergent (e.g., Fab<sup>®</sup>, Tide<sup>®</sup>, or equivalent powder detergent)\*
  - 2/3 cup powdered household cleaner (e.g., Soilax<sup>®</sup>, Spic & Span<sup>®</sup>, or equivalent)\*
  - 1 gallon water
3. If mildew is a problem, use the solution previously mentioned, but add 1 quart liquid laundry bleach.
4. When washing down your entire house, start at the bottom and work up to the top in order to prevent streaking.
5. For stubborn stains, use the following chart:

*\* Cleaning materials are listed in alphabetical order.*



<b>STAIN</b>	<b>CLEANERS*</b>
Bubble Gum	Fantastik®, Murphy's Oil Soap®, or solution of vinegar (30 percent) and water (70 percent)
Crayon	Lestoil®
DAP (Oil-based caulk)	Fantastik®
Felt-tip Pen	Fantastik® or water-based cleaners
Grass	Fantastik®, Lysol®, Murphy's Oil Soap®, or Windex®
Lipstick	Fantastik® or Murphy's Oil Soap®
Lithium Grease	Fantastik®, Lestoil®, Murphy's Oil Soap®, or Windex®
Mold and Mildew	Fantastik® or solution of vinegar (30 percent) and water (70 percent)
Motor Oil	Fantastik®, Lysol®, Murphy's Oil Soap®, or Windex®
Oil	Soft Scrub®
Paint	Brillo® Pad or Soft Scrub®
Pencil	Soft Scrub®
Rust	Fantastik®, Murphy's Oil Soap®, or Windex®
Tar	Soft Scrub®
Top Soil	Fantastik®, Lestoil®, or Murphy's Oil Soap®

*\*Cleaning materials are listed in alphabetical order.  
SPI does not endorse proprietary products or processes and makes no warranties for the products referenced herein. Reference to proprietary names is for illustrative purposes only and is not intended to imply that there are not equally effective alternatives.*

Follow the precautionary labeling instructions on the cleaning agent container. Protect shrubs from direct contact with cleaning agents.

## **Disposal**

Dispose of all scrap or excess trim in a manner that is consistent with local and state rules and regulations. For information on recycling leftover vinyl siding scrap, order a how-to guide from the American Plastics Council, at 1-800-243-5790, or the Vinyl Siding Information Center, at 1-888-FOR-VSI-1 (1-888-367-8741).

## TERMS TO KNOW

**Backerboard**—a flat material used on the face of the house, applied between the studs and the siding (or over existing wall surface), to provide an even surface for installing vinyl siding.

**Buttlock**—the bottom edge of a siding or soffit panel, or accessory piece, opposite the nailing slots, which locks onto to the preceding panel.

**Channel**—the area of the accessory trim or corner post where siding or soffit panels are inserted. Channels also refer to the trim itself, and are named for the letters of the alphabet they resemble (e.g., J-channel, F-channel, etc.).

**Course**—a row of panels, one panel wide, running the length of the house from one side to the other, or, in the case of vertical siding, from top to bottom.

**Drip Cap/Head Flashing**—an accessory installed with vertical siding to ensure that water drips away from panels and does not infiltrate them; it is also used as a vertical base.

**Double Channel Lineal**—a siding accessory that joins two soffit panels.

**Face**—refers to the side of a siding or soffit panel that is showing once the panel has been installed.

**Face-nailing**—the action of fastening directly onto the “face” side of a panel (instead of

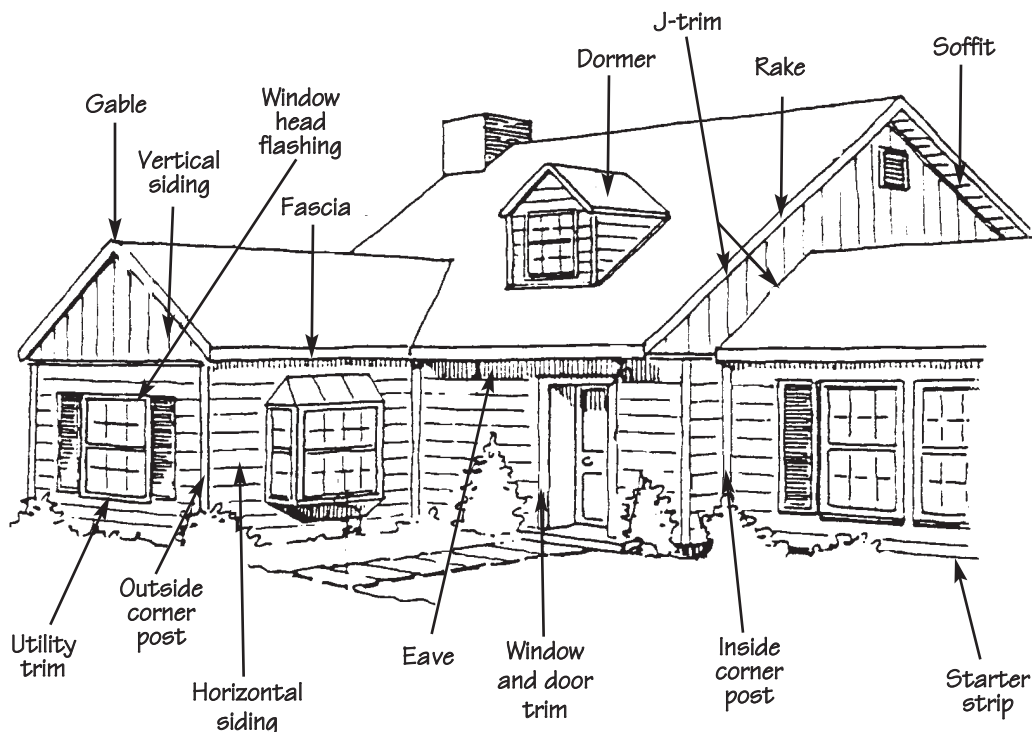

Figure 2.

using the nail hem slot). This practice is generally not used in siding installation.

**Fascia Board**—a board attached to the ends of the rafters between the roofing material and the soffit overhang. Fascia cap is the covering around that board.

**Flashing**—a thin, flat material, usually aluminum, positioned under or behind J-channels, corner posts, windows, etc., to keep draining water from penetrating the home.

**Furring/Furring Strip**—usually a wood 1" x 2" strip used to even a surface in preparation for installing vinyl siding. To “fur” a surface means to apply these strips.

**Lap**—to overlap the ends of two siding panels or accessory pieces to allow for expansion and contraction of the vinyl product.

**Lug/Crimp**—the raised “ears” or tabs on a siding panel, created by a snap lock punch, which can be used to lock a siding panel into place when the nailing hem has been removed.

**Miter**—to make a diagonal cut, beveled to a specific angle (usually 45°). Sometimes miter cuts are made into an overlapping siding or soffit panel surface, to provide a neater appearance.

**Nailing Hem (or Flange)**—the section of siding or accessories where the nailing slots are located.

**Plumb**—a position or measurement that is truly and exactly vertical, 90° from a level surface.

**Scoring**—running a utility knife blade, a sharpened awl, scoring tool, or other sharp implement across a soffit or siding panel face without cutting all the way through the panel. This weakens the vinyl surface in a specific area and allows the panel to be bent and broken off cleanly.

**Shim**—a building material used to even a surface prior to installing vinyl siding.

**Soffit**—material used to enclose the horizontal underside of an eave, cornice, or overhang. Soffit is designed to be installed lengthwise from wall to fascia.

**Starter Strip**—an accessory applied directly to the surface of the building and used to secure the first course of siding to the home.

**Underlayment**—weather-resistant material placed under vinyl siding panels.

**Utility Trim**—a piece of trim used any time the top lock has been removed from the siding, to secure a siding panel. Also referred to as “undersill” or “finish” trim.

**Weep Holes**—openings cut into siding or accessories to allow for water runoff.

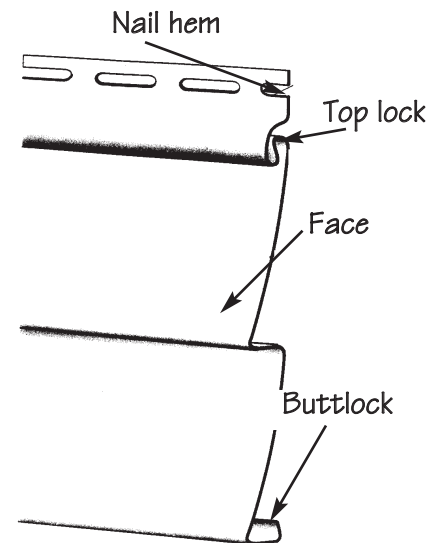

Figure 3.

# MATERIALS, TOOLS, AND ACCESSORIES

## Basic Installation Tools and Equipment

Common hand tools, such as a hammer, fine-tooth saw, square, chalkline, level, and tape measure, are needed for proper installation (Fig. 4). Safety glasses are recommended for eye protection. Other basic tools include:

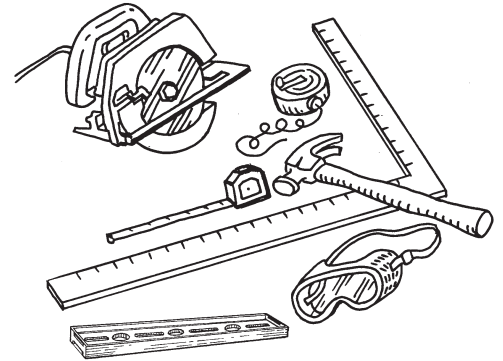

Figure 4.

### Power Saw

A bench or radial-arm power saw can speed the cutting of the siding. A fine-tooth blade (12 to 16 teeth per inch) should be used with the blade installed in the reverse direction. Some applicators prefer a hand-held power saw. In extremely cold weather, move the saw through the material slowly to prevent chipping or cracking (Fig. 5).

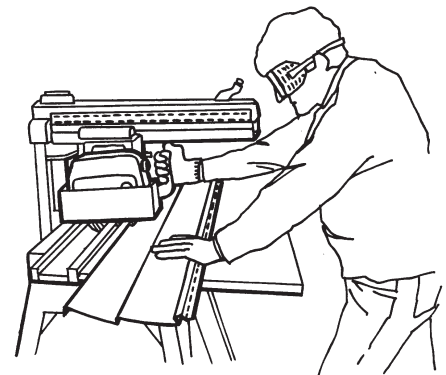

Figure 5.

**NOTE:** A saw blade set up in reverse direction should be used only for cutting vinyl. DO NOT attempt to use it on other materials such as wood, plywood, etc.

### Utility Knife

Vinyl is easy to cut, trim, and score with a utility knife or scoring tool (Fig. 6).

### Tin Snips

Good quality tin snips or compound aviation-type snips will speed the cutting and shaping of the vinyl (Fig. 6).

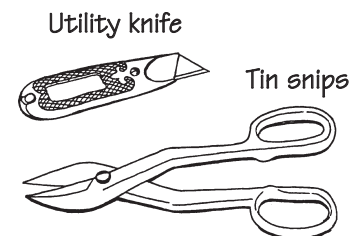

Figure 6.

## Special Tools

### Snap Lock Punch

A snap lock punch is used to punch lugs in the cut edges of siding to be used for the top or finishing course at the top of a wall, or underneath a window (Fig. 7).

### Nail Hole Slot Punch

Occasionally, it may be necessary to elongate a nail hem slot. The hole is elongated to allow for expansion and contraction (Fig. 7).

### Unlocking Tool (Zip-Lock Tool)

Remove or replace a siding panel with the unlocking tool. Insert the curved end of the tool under the end of the panel and hook onto the back lip of the buttlock. To disengage the lock, pull down and slide the tool along the length of the panel. Use the same procedure to relock a panel (Fig. 7).

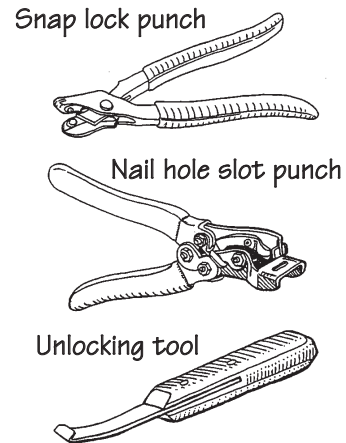

Figure 7.

## Accessories

### Outside and Inside Corner Posts

Corner posts are used to provide a finished edge at an inside or outside corner. The siding from adjoining walls fits neatly into the inside or outside corner post channels. Appropriate widths of channel openings are available to accommodate various configurations of siding.

### Trim and Molding

A complete line of accessories is used to give every installation a professional appearance, while providing a weather-resistant facade. Some accessories include trim, starter strips, molding, F-channels, drip caps, and J-channels (Fig. 8). Each of these accessories will be addressed in more detail throughout this manual.

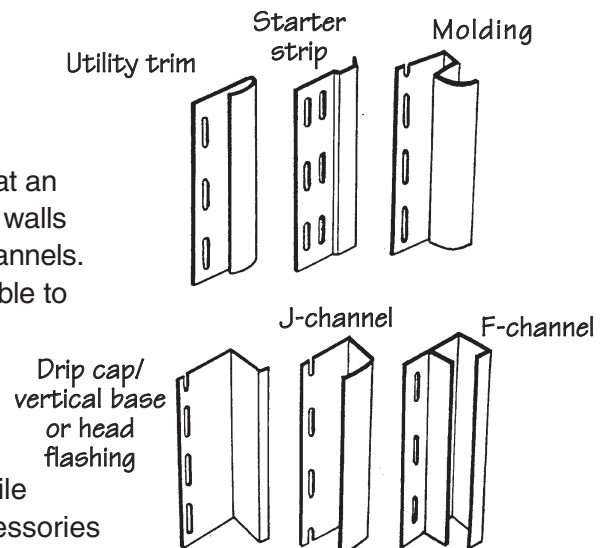

Figure 8.

**Note:** Vinyl siding manufacturers produce various sizes of J-channels and corner posts. Remember to order accessories of the proper size to match the siding panels. Consult the manufacturer for the appropriate size.

## Sheathing/Backerboard

Vinyl siding should be applied over a sheathing that provides a smooth, flat surface. Consult local building codes for sheathing requirements. Vinyl siding should never be applied directly to studs without sheathing. As an alternative, installation of specific types of contoured foam underlayments for various styles of vinyl siding are available. Some manufacturers of vinyl siding do not recommend the use of drop-in backers with certain vinyl siding configurations.

## Weather Barrier

Vinyl siding should be installed over a continuous weather-resistant barrier to stop the intrusion of incidental water. See your local building code official for requirements in your area.

## Flashing

Code-compliant flashing should be integrated with the weather-resistant barrier and applied around windows, doors, and other openings. Flashing should also be applied to inside and outside corners, and the intersection of walls and roofing to prevent water infiltration.

# GETTING STARTED

## How to Measure

### Estimating Required Materials

- All houses can be broken down into shapes of rectangles or triangles, or a combination of both.
- The area to be sided can be determined by measuring the height and width of the house, including windows (Fig. 9).
- Total all of the measurements for the areas to be sided. Windows and doors are not usually deducted. Including them will provide an allowance factor for waste. If the windows and doors are extremely large (such as a garage or sliding glass doors), some deductions can be made. (Fig. 10-12).

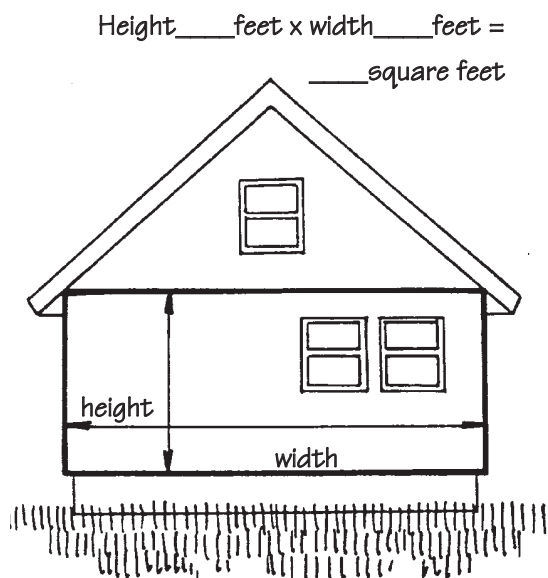

Figure 9. Wall Areas

$\frac{1}{2}$  height x width = \_\_\_\_ area of gable (square feet)

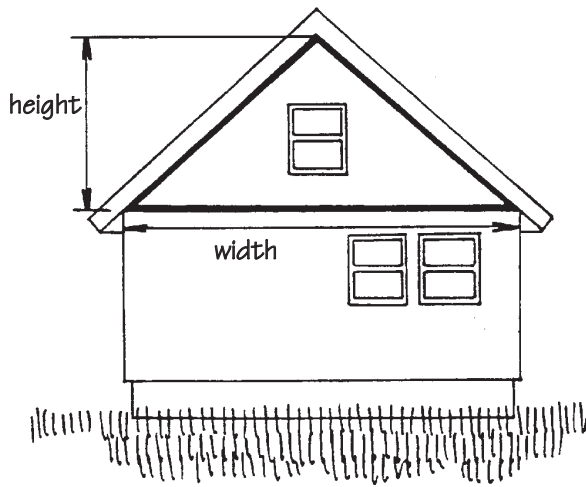

Figure 10. Gable areas

$\frac{1}{2} (A + B) \times C + \frac{1}{2} B \times D =$  \_\_\_\_ total area of gable (square feet)

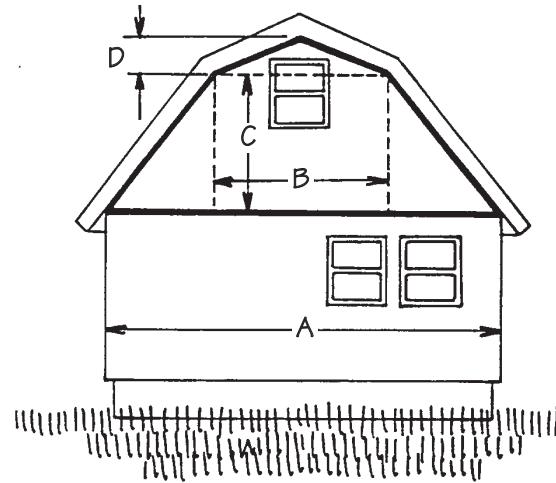

Figure 11. Gambrel roof house

- To estimate the amount of starter strip required, measure the linear feet around the entire base of the house.
- Add a factor of 10 percent to all material estimates to allow for waste.

$\frac{1}{2}$  height x width = \_\_\_\_ area of dormer (square feet)

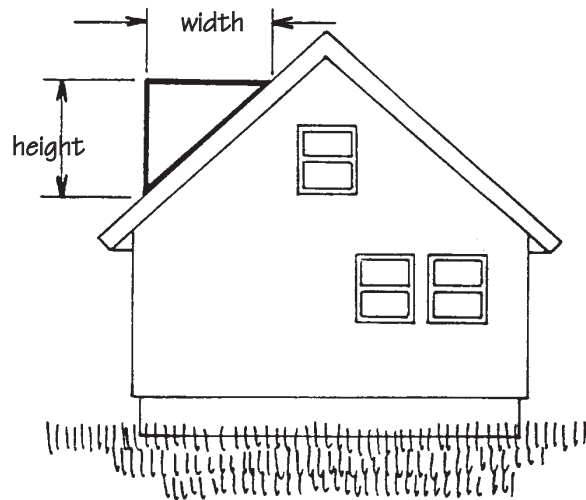

Figure 12. Dormer areas



# Estimating Worksheet

Use the following worksheet to estimate the required materials\*:

<b>Siding</b>	Walls	_____ square feet	
	Gable ends	_____ square feet	
	Dormer sides	_____ square feet	
	Upper gambrel walls	_____ square feet	
	Total wall surface area	_____ square feet (A)	
	Large areas not to be covered: (garage doors/sliding doors)	_____ square feet	
		x 0.50 =	
	Uncovered area	_____ square feet (B)	
	Subtract B from A for		
	<b>Total net surface area</b>	_____ square feet	
<b>Soffit</b>		_____ square feet	
<b>Porch Ceiling</b>		_____ square feet	
<b>Lattice</b>		_____ linear feet	
<b>Accessories</b>	Starter strip	_____ linear feet	
	Utility trim	_____ linear feet	
<b>Receiving channel</b>	J-channel	_____ linear feet	
	Designer J-channel	_____ linear feet	
	Flexible J-channel	_____ linear feet	
	F-channel	_____ linear feet	
	3 1/2" /5" lineals	_____ linear feet	
	Dual undersill trim	_____ linear feet	
<b>Outside corners</b>	Outside corner post	_____ linear feet	
	Designer corner trim	_____ linear feet	
	Restoration corners	_____ linear feet	
<b>Inside corners</b>	Inside corner post	_____ linear feet	
	J-channel	_____ linear feet	
<b>Other</b>	Soffit cove trim	_____ linear feet	
	Soffit double channel lineal	_____ linear feet	
	U-channel (for lattice)	_____ linear feet	
	Light blocks	_____	
	Width of accessory recess opening: (circle one)    1/2"    5/8"    3/4"    1 1/4"		
<b>Nails</b>	Pounds required		
	Length (1 1/2" minimum)	_____	
<b>Tools needed</b>	___ hammer	___ tin snips	___ tape measure
	___ chalkline	___ utility knife	___ level
	___ square	___ hacksaw	___ power saw
	___ nail hole slot punch	___ snap lock punch	
	___ unlocking tool	___ fine-tooth saw blade	

\* Add a factor of 10 percent to all material estimates to allow for waste.

## Fastener Choices

Use aluminum, galvanized steel, or other corrosion-resistant nails, staples, or screws when installing vinyl siding. Aluminum trim pieces require aluminum or stainless steel fasteners. All fasteners must be able to penetrate not less than 3/4" into framing or furring (Fig. 13). (Review your local building codes for variations that may apply to specific geographic areas.)

### Nails

Nail heads should be 5/16" minimum in diameter. Shank should be 1/8" in diameter (Fig. 13).

### Screw Fasteners

Screw fasteners can be used if the screws do not restrict the normal expansion and contraction movement of the vinyl siding panel on the wall. Screws must be centered in the slot with a minimum 1/32" space between the screw head and the vinyl. Screws must be able to penetrate not less than 3/4" into framing or furring and should be:

- Size #8, truss head or pan head.
- Corrosion-resistant, self-tapping sheet metal type.

Figure 13

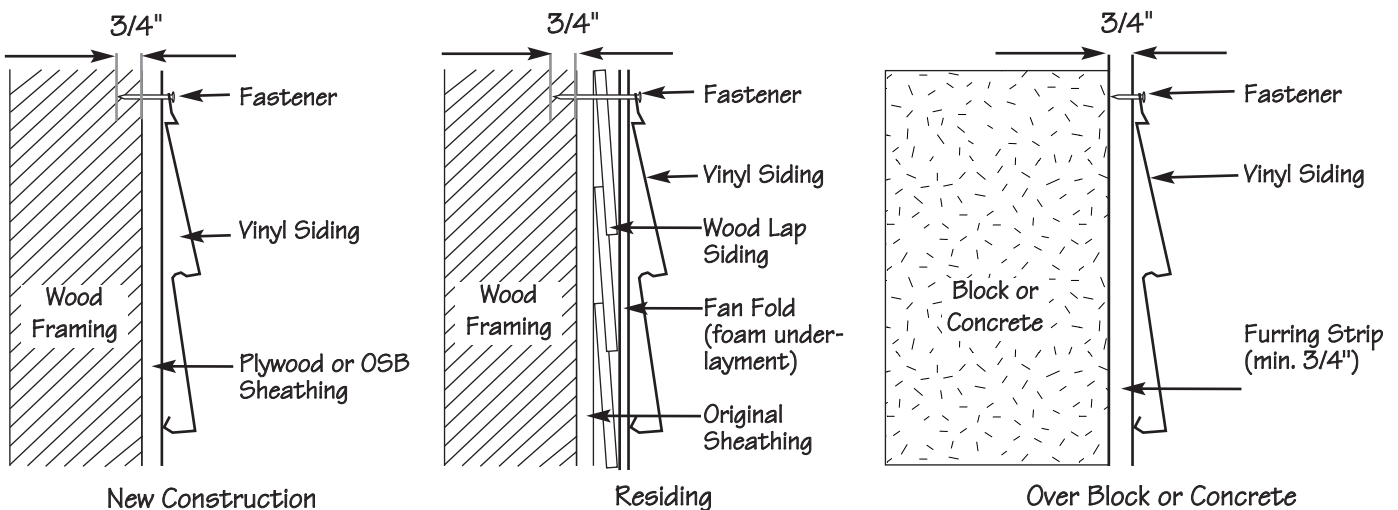
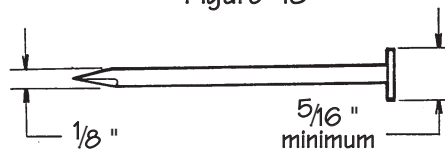

## Fastening Procedure

Vinyl siding can expand and contract 1/2" or more over a 12' 6" length with changes in temperature. Whether using a nail, screw, or staple to fasten the siding, the following basic rules must be followed:

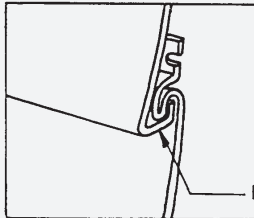

■ Make sure the panels are fully locked along the length of the bottom, but do not force them up tight when fastening.

- Do not drive the head of the fastener tightly against the siding nail hem. Leave a minimum of 1/32" (the thickness of a dime) between the fastener head and the vinyl. **Tight nailing, screwing, or stapling will cause the vinyl siding to buckle with changes in temperature (Fig. 14).**
- When fastening, start in the center of the panel and work toward the ends.
- Center the fasteners in the slots to permit expansion and contraction of the siding (Fig. 15).
- Drive fasteners straight and level to prevent distortion and buckling of the panel (Fig. 16).
- Space the fasteners a maximum of 16" apart for the horizontal siding panels, every 12" for the vertical siding panels, and every 8" to 10" for the accessories. Start fastening vertical siding and corner posts in the top of the uppermost slots to hold them in position. Place all other fasteners in the center of the slots (Fig. 17).

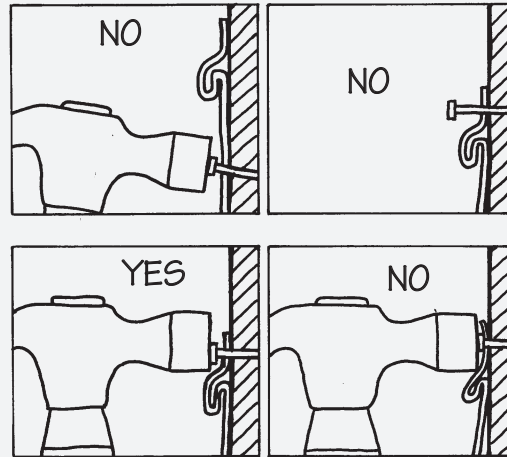

Figure 14.

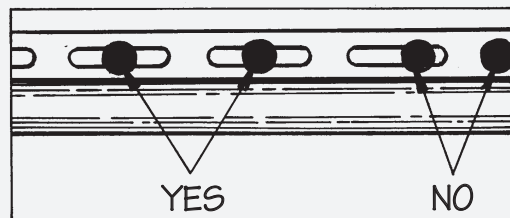

Figure 15.

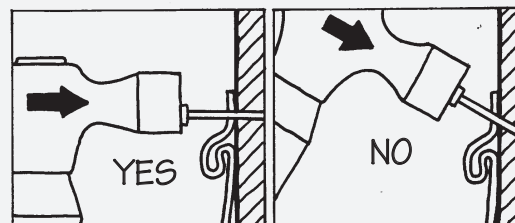

Figure 16.

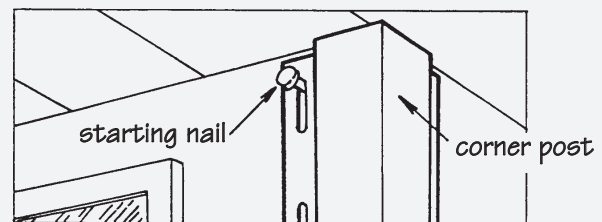

Figure 17.

## Staples

If staples are being used instead of nails or screws, they must (Fig. 18):

- Not be less than 16-gauge semi-flattened to an elliptical cross-section.
- Penetrate not less than 3/4" into framing or furring.
- Be wide enough in the crown to allow free movement of the siding (1/32" away from the nailing hem).

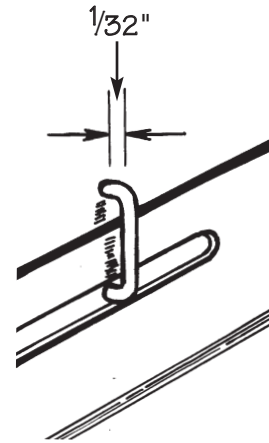

Figure 18.

## Cutting the Siding

When cutting vinyl siding, follow these guidelines:

- Safety goggles are always recommended for all cutting and nailing operations. As on any construction job, use proper safety equipment and follow safe construction practices.
- With a circular saw, install the fine-toothed (plywood) blade backwards on the saw for a smoother, cleaner cut, especially in cold weather. (Fig. 19.) Cut slowly. Do not attempt to cut materials other than vinyl with a reversed direction saw blade.

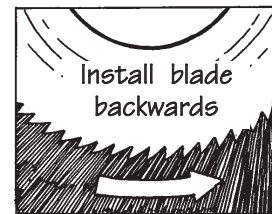
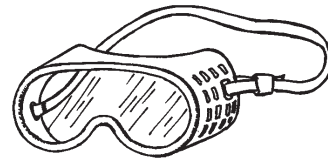

Figure 19.

**Caution! Use of a backwards blade on any other materials could be unsafe.**

- With tin snips, avoid closing the blades completely at the end of a stroke for a neater, cleaner cut (Fig. 20).
- With a utility knife or scoring tool, score the vinyl face up with medium pressure and snap it in half. It is not necessary to cut all the way through the vinyl (Fig. 21).

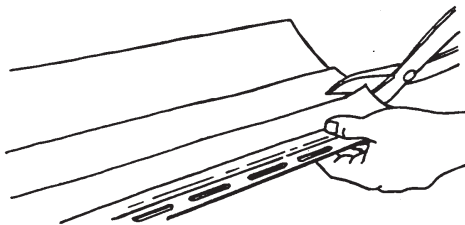

Figure 20.

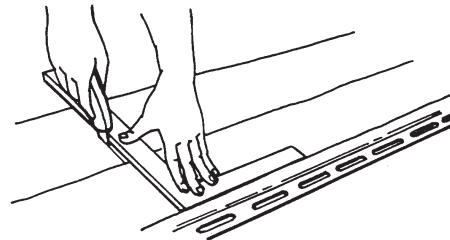

Figure 21.

## Preparing the Walls

A flat, level wall surface is necessary for proper installation of vinyl siding. Install flashing **before** starting to apply the siding.

### New Construction

- A weather-resistant barrier should be applied to the house prior to installing vinyl siding. Consult your local building code official for requirements in your area.
- Tip: To reduce the possibility of the floor-plate compression, dry-wall, roofing, or other heavy building materials should be installed or stored throughout the house prior to the installation of vinyl siding. Floor-plate compression can result in buckled siding at the intersection of the floor and the wall.

### Residing

- Nail down loose boards of existing siding, and replace any rotten ones (Fig. 22). **Do not install vinyl siding over rotting wood.**
- Scrape off loose caulk and re-caulk around windows, doors, and other areas to protect from moisture penetration.
- Remove all protrusions such as gutters, downspouts, and light fixtures.
- Check all walls for evenness and install furring strips where necessary (Fig. 23).

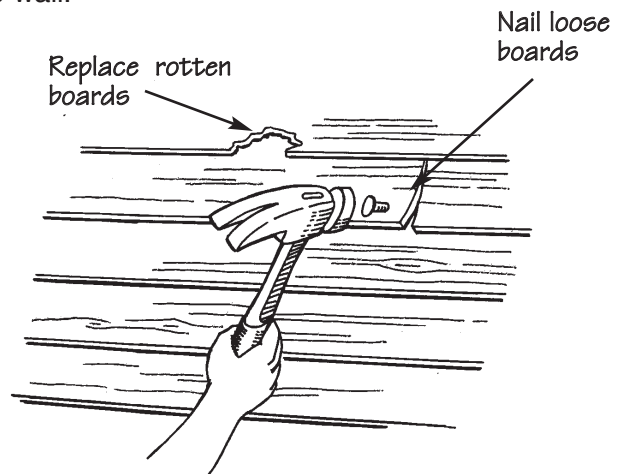

Figure 22.

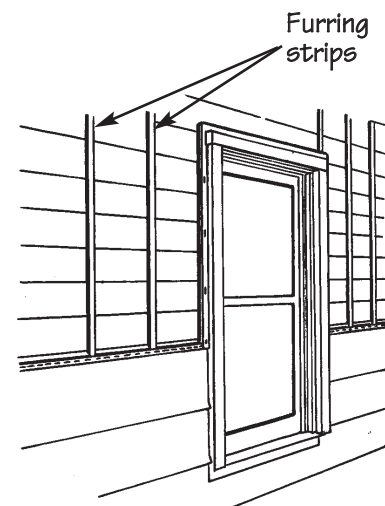

Figure 23.

**NOTE:** In cases where the lower portion of a horizontal siding panel must be trimmed so that it may be installed over steps, porches, etc., the panel should be built out (“furred”) for proper angle and rigidity. Utility trim can be used to seal the cut edge of the panel and then secured to the wall.

## INSTALLING ACCESSORIES

Before the siding itself can be hung, a number of accessories must be installed first, including starter strips, corner posts, window flashing, trim, and J-channels over the roof lines.

### Starter Strip

In order for the siding to be installed properly in a level fashion, the starter strip at the bottom of the wall must be level.

- Determine the lowest point of the wall that will be sided; from that point, measure up 1/4" less than the width of the starter strip and partially drive a nail at one corner.
- Attach a chalkline; go to the next corner and pull the line taut.
- Make sure the line is level by using a line level or a 4' level.
- Snap the chalkline and repeat the procedure around the entire house.
- Optional method to determining the position of the starter strip in new construction and some residing applications: Measure down from the soffit at one corner of the house to the top of the foundation and subtract 1/4" and the width of the starter strip. Make a mark on the wall and record the measurement. Transfer the measurement to the other corner of the wall. Snap a chalk line in between the corners at the marks. Repeat the procedure around the entire house.
- Using the chalkline as a guide, install the top edge of the starter strip along the bottom of the chalkline, nailing at 10" intervals. Allow space for the corner posts, J-channels, etc.
- Keep the ends of starter strips at least 1/4" apart to allow for expansion (Fig. 24).
- Nail in the center of the starter strip nailing slots.

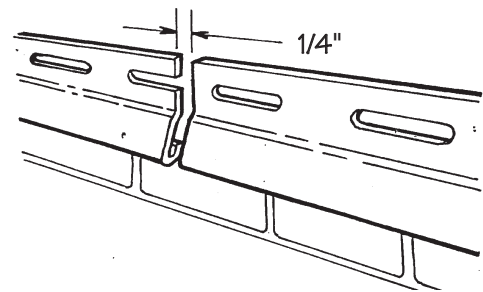

Figure 24.

**NOTE:** When insulation or backerboard is used, fur the starter strip, if necessary, to accommodate thickness. For a vertical siding starter strip, see the section on vertical siding.

**NOTE:** In certain situations, it may be necessary to use J-channel as a starter strip; remember to drill 1/4" weepholes every 24".

## Outside and Inside Corner Posts

- A water-resistant material should be used to flash the inside and outside corners a minimum of 10" on each side before installation of the corner posts (Fig. 25).

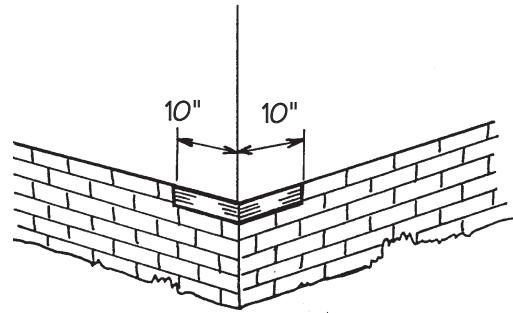

Figure 25.

**NOTE:** Install vinyl soffit and fascia before installing outside and inside corner posts.

- Place the corner post in position, allowing a 1/4" gap between the top of the post and the eave or soffit. Position a nail at the top of the upper slot on both sides of the corner post, leaving a 1/32" gap between the nail heads and the corner posts. The corner post hangs from these nails. The balance of the nailing should be in the center of the slot, 8" to 12" apart, again leaving 1/32" between the nail head and the corner post. This allows for the expansion and contraction to occur at the bottom. The corner post should extend 3/4" below the starter strip. Make sure the posts are plumb (i.e., vertically straight) (Fig. 26 and 27).

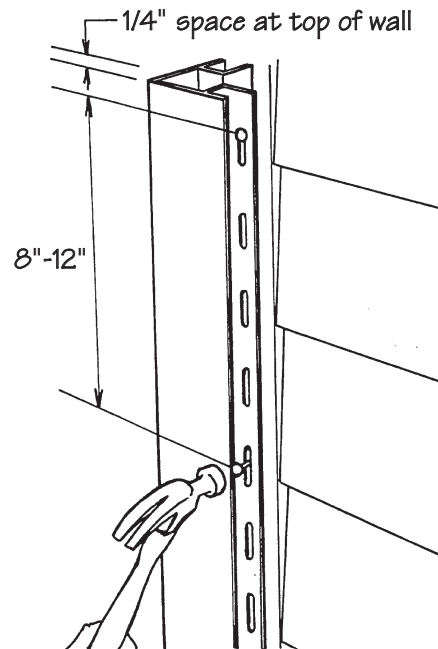

Figure 26.

- If more than one length of corner post is required, overlap the upper piece over the lower piece by cutting away 1" of the nailing flange on the top piece. Overlap 3/4", allowing 1/4" for expansion. This method will produce a visible joint between the two posts, but will allow water to flow over the joint, reducing the chance of water infiltration.

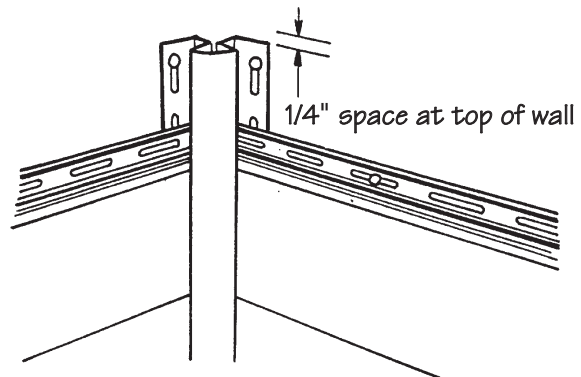

Figure 27.



## Windows, Doors, and Roof Lines

### Window Flashing

The following instructions should be followed when applying window flashing:

- Apply the flashing on the underside of the window first (Fig. 28).
- Follow this application with flashing on the sides of the window. Make sure to overlap the bottom flashing (Fig. 29).
- Finally, apply the flashing at the top of the window.

The flashing should extend past the nail flanges of any accessory to prevent water infiltration through the opening. The flashing should be long enough to direct water over the nail flange of the last course of siding (Fig. 30). Use this example as a model for applying flashing to other openings such as electrical outlets and doors.

### Trim

J-channel is used around windows and doors to receive the siding. Follow the steps below when applying trim.

- Cut and bend the tab of the top piece of J-channel down to provide flashing over the side J-channel.
- Fold the bottom end of the side piece of J-channel inward at the bottom of the window, to fit over the existing J-channel to prevent water from entering under the sill.

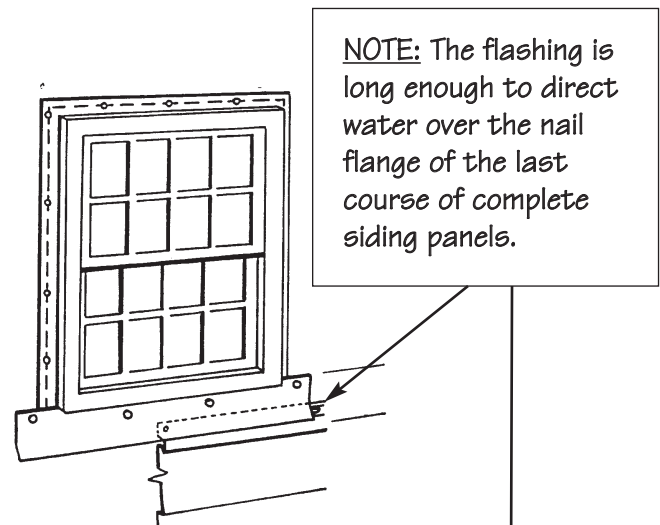

Figure 28.

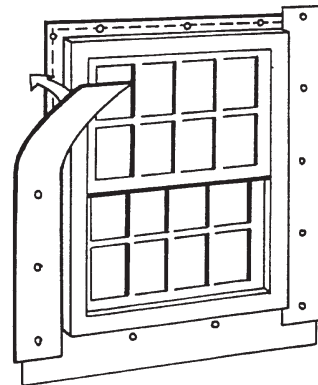

Figure 29.

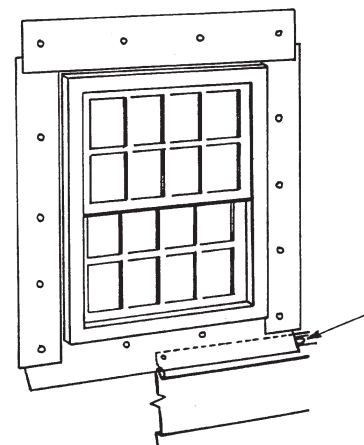

Figure 30.

- Cut the side J-channel members longer than the height of the window or door, and notch the channel at the top.
- Miter cut the free flange at a 45° angle and bend the tab down to provide flashing over the side members (Fig. 31). A similar miter and tab may be provided at the bottom of the window, depending on the sill's condition. The J-channel should fit snug to the window.

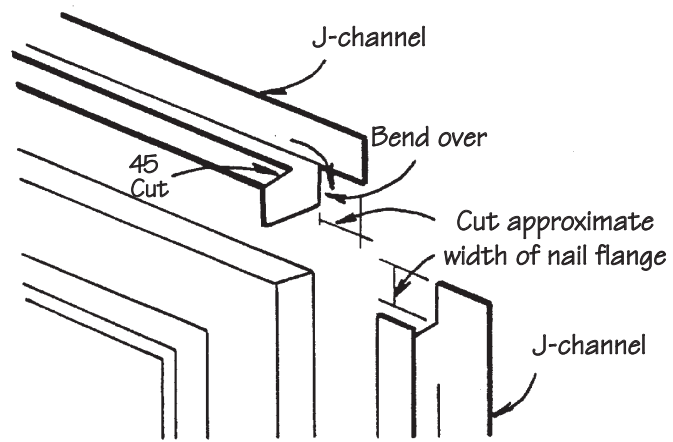

Figure 31.

### J-Channel Over Roof Lines

- Install the flashing before the J-channel to prevent water infiltration along the intersection of a roof and wall.
- Keep the J-channel approximately 1/2" from the roof line. Chalk a straight line up the roof flashing to guide J-channel installation. Tip: You can use another J-channel laid over the shingles as a spacer to create the straight line desired.
- Overlap the J-channel (lapping the upper piece over the lower piece) if it is necessary to use more than one piece.
- Extend the J-channel past the edge of the roof, channeling water into the gutter, in order to ensure proper runoff.
- With dark shingles, or a south or west exposure, it is recommended to either use a metal J-channel or to install the vinyl J-channel as far away from the roofing as is aesthetically acceptable, having first ensured that there is sufficient flashing behind the J-channel to prevent water infiltration.

*NOTE: Vinyl J-channels should not be in direct contact with roofing shingles, since the shingles may transfer enough heat to the vinyl J-channel to cause its distortion.*

- Fasten the nail, screw, or staple that is closest to the roof line at the far end of the nail hem slot, to ensure that siding will expand away from the J-channel (Fig. 32).

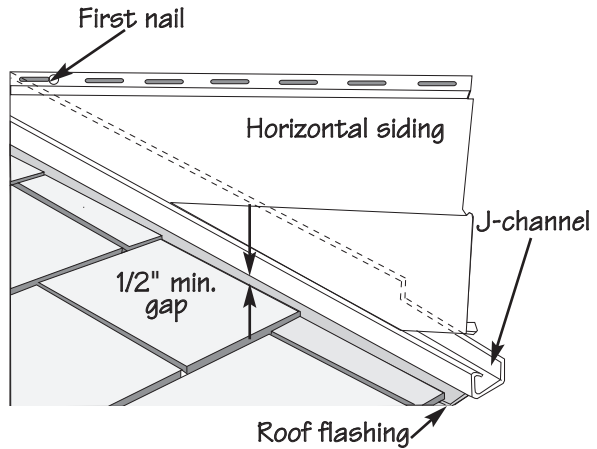

Figure 32.

## Gable and Trim

Before applying siding to the gables, the J-channel should be installed to receive the siding at the gable ends (Fig. 33):

- Where the left and right sections meet at the gable peak, let one of the sections butt into the peak with the other section overlapping.
- A miter cut should be made on the face flange of this piece for better appearance.
- Fasten the J-channel every 8" to 12".
- If more than one length of J-channel is required to span a wall surface, be sure to overlap the J-channels by 3/4".

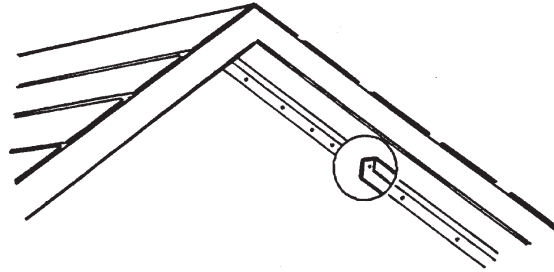

Figure 33.

# HORIZONTAL SIDING INSTALLATION

## Installing Panels

- The first course (row of panels) should be placed in the starter strip and securely locked along the entire length of the siding panel. Make sure the panel is securely locked before fastening.
- Fasten the panels in the center of the nailing slots (see page 14 for specific information on fastening and fasteners). Allowance should be made for expansion and contraction by leaving a 1/4" gap between the siding and all corner posts and channels (increase to 3/8" when installing in temperatures below 40°F).
- Do not drive the head of the fastener tightly against the nail slot. Leave 1/32" between the fastener head and the vinyl.
- Do not force the panels up or down when fastening. Panel locks should be fully engaged; however, the panels should not be under vertical tension or compression when they are fastened.

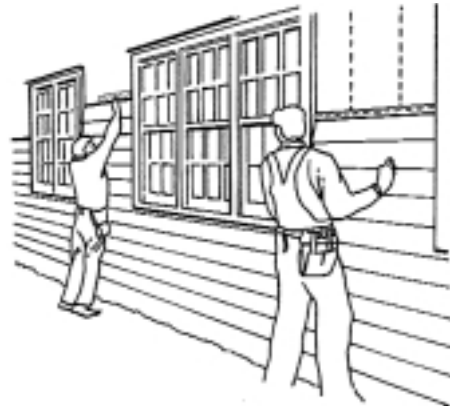

Figure 34.

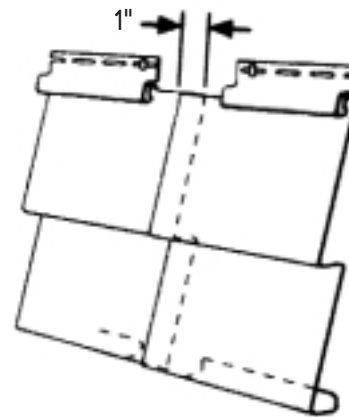

Figure 35.

- Since vinyl siding moves as the temperature changes, make certain that the vinyl panels can move freely in a side-to-side direction once fastened.
- Check every fifth or sixth course for horizontal alignment (Fig. 34). Also check siding alignment with adjoining walls.
- When panels overlap, make sure they overlap by one half the length of the notch at the end of the panel, or approximately 1" (Fig. 35).
- Stagger the siding end laps so that no two courses (rows of panels) are aligned vertically, unless separated by at least three courses (rows of panels).

- Always overlap joints away from entrances and away from the point of greatest traffic. This will improve the overall appearance of the installation (Fig. 36).

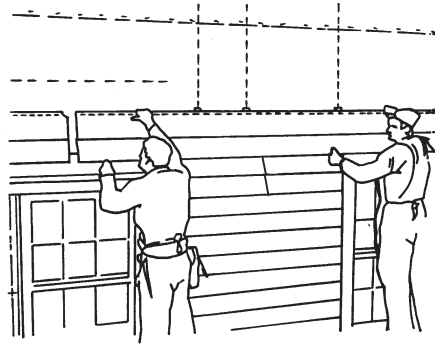

Figure 36.

## Fitting Siding Around Fixtures

For handling protrusions around the wall, refer to the figure (Fig. 37) for hand fabricating, or use manufacturers' accessories specifically designed for this purpose. In addition, VSI suggests the following tips:

- Always begin a new course of siding at the fixture to avoid excess lap joints.
- Cut a slot 1/4" bigger than the fixture.
- When cutting, match the shape and contour of the obstruction.

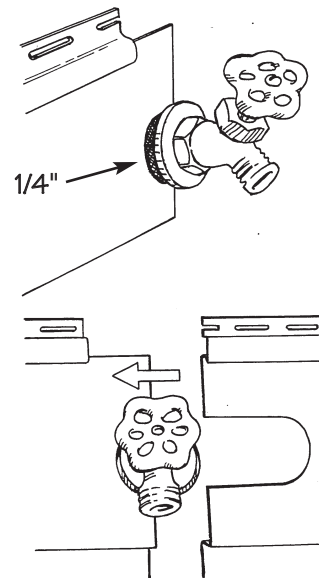

Figure 37.

## Fitting Under Windows

To mark the section to be cut, perform the following:

- Hold the panel under the window and mark the width of the window opening on the panel. Add approximately 1/4" to both sides to allow for expansion and contraction of the siding. These marks represent the vertical cuts (Fig. 38).
- Lock a small piece of scrap siding into the lower panel next to the window. This will be used as a template for the horizontal cuts. Mark it 1/4" below the sill height.
- Transfer the horizontal measurement to the panel, which will be installed under the window. Measurement may not be the same on both sides of the window.
- Cut the panel with tin snips and a utility knife.

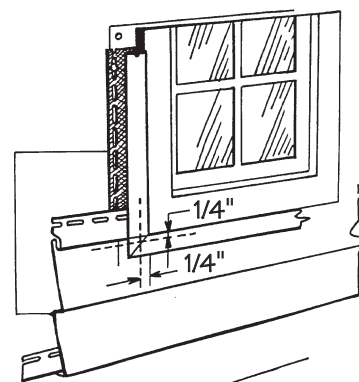

Figure 38.

The cut panel is now ready for installation under the window. Perform the following:

- Using a snap lock punch, punch the vinyl siding along the cut edge every 6" so the raised lug is on the outside face.
- Install utility trim under the window, as a receiver for the cut siding. Utility trim is used any time the top lock has been removed from the siding. Furring may be needed to maintain the face of the panel at the desired angle.
- Install the siding panel, making sure the lugs (from the snap lock punch) lock into the utility trim (Fig. 39).

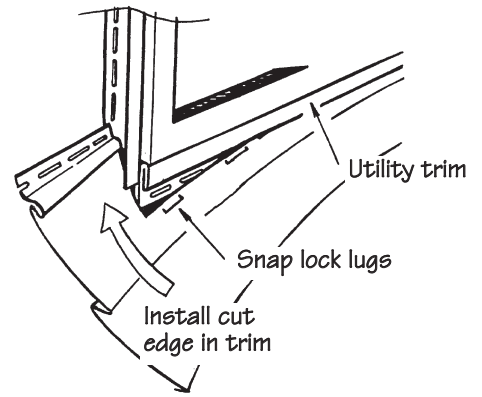

Figure 39.

### Sidewall Flashing at Roof Lines

- Run the siding until the last full course under the roof area.
- Cut a diverter from aluminum trim sheet, making sure it sits on the nail hem of the last full course (Fig. 40). Also make sure to slip it behind all J-channels and roof flashing (similar to flashing the bottom of window detail shown on page 19).
- Cut the next piece of siding, making sure the vertical lap falls behind the roof flashing and roof J-channel (Fig. 41).
- Cut a small piece of siding that will be placed on top of the previous piece of siding and sits in the roof J-channel (Fig. 42).

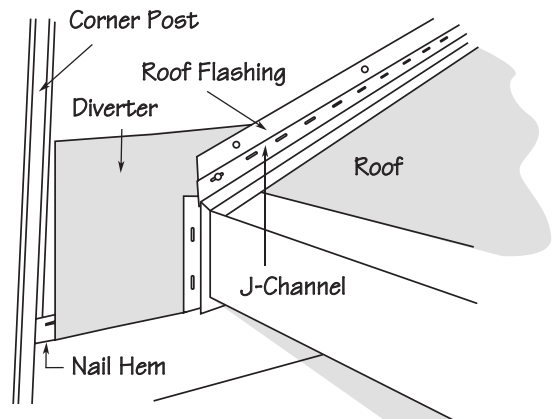

Figure 40.

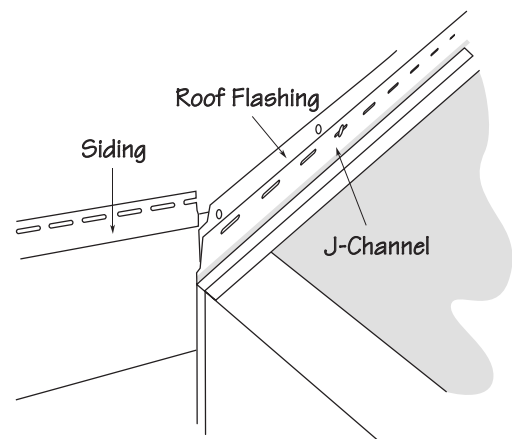

Figure 41.

- Install the remaining course of siding. Water running behind the panel will be directed by the diverter into the butt of the panel, draining out in the weep holes.

## Finishing at the Top

Before the final course of siding is installed on the wall, any soffit accessories that will be used on the eaves must be installed. See the soffit installation section.

## Gable Ends

To install around gable ends, make a pattern that duplicates the slope of the gable (Fig. 43):

- Lock a short piece of siding into the gable starter course (i.e., the last course before the gable starts).
- Hold a second piece of siding against the J-channel at the slope of the gable. Mark the slope with a pencil on the short piece of siding. Check the angle template every few courses.
- Remove the short piece and cut along the pencil line as a pattern for the gable angle cuts. Repeat the procedure on the opposite side of the gable.
- It may be necessary to fasten the last panel at the gable peak with a trim nail. Use a 1 1/4" to 1 1/2" nail. This is the only time a nail should be placed in the face of the vinyl siding (Fig. 44).

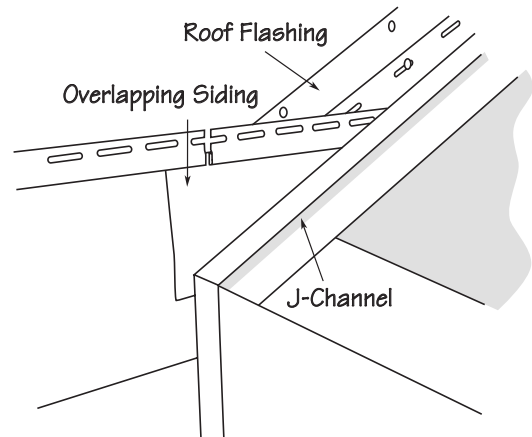

Figure 42.

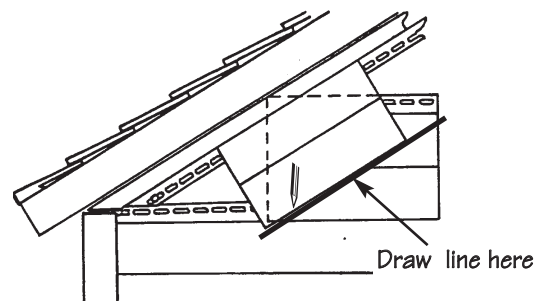

Figure 43.

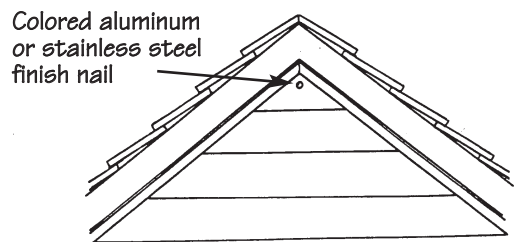

Figure 44.



## Eaves Treatment

The last course of siding may be cut to fit the eaves opening (Fig. 45).

- Measure from the soffit to the base of the upper lock on the previous course of panels. Subtract 1/4". Mark this dimension on the panel to be cut, measuring from the bottom edge of the panel. It is a good idea to check the dimension in several locations along the length of the wall.
- Using a snap lock punch, punch the vinyl siding along the cut edge every 6", so the raised lug is on the outside face.
- Push the siding into the utility trim that has been nailed in place along the top of the wall. Furring may be needed to maintain the face of the panel at the desired angle. The raised lugs will catch and hold the siding firmly in place.

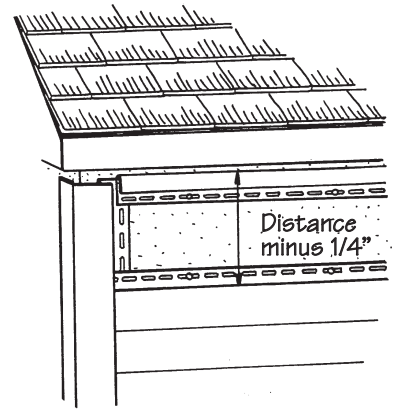

Figure 45.

## Transition from Horizontal to Vertical

- Finish the last course of horizontal siding with the J-channel and/or finish trim. Install a drip cap and a J-channel. The top piece of J-channel must have 1/4" weep holes drilled every 24" to allow for water runoff.

## Transition from Brick to Vinyl Siding

- Caulk where the sheathing meets the brick or stone exterior. Flashing should be caulked where it meets the brick or stone and a drip cap should be in place.
- If horizontal siding is used, a J-channel or starter strip may be used. If starter strip is used, it is necessary to provide at least 3/8" clearance for proper engagement of the siding.
- Use a J-channel to receive vertical siding; remember to drill 1/4" weep holes every 24".

# VERTICAL SIDING AND ACCESSORIES INSTALLATION

## Preparation

See section "Preparing the Walls" on page 16. When installing vertical siding, however, follow these additional preparatory steps:

- Install horizontal furring strips, 12" on center, or a solid nailable sheathing prior to the siding, if needed, to level the surface or provide sufficient material for 3/4" fastener penetration.
- Snap a level chalkline around the base of the sidewalls. Typically, the chalkline is positioned so that the bottom of the J-channel that will serve as a vertical starter strip is 1/4" below the lowest point on the wall that will be sided. (See the "Installing Accessories" section for tips on snapping a chalkline.) Install a J-channel along the chalkline as a receiver for the vertical siding.

## Accessories

As with horizontal siding, when installing vertical siding it is necessary to install several accessories first, including corner posts and window, door, and roof trim.

### Outside and Inside Corner Posts

- Leave 1/4" gap at the top of corner posts.
- Place the first nails in the uppermost end of the top nail slots to hold them in position (Fig 46). Place all other nails in the center of the slots. Nails should be 8" to 12" apart.
- Corner posts should extend 3/4" below the siding. Do not nail tightly; the corner post should move.

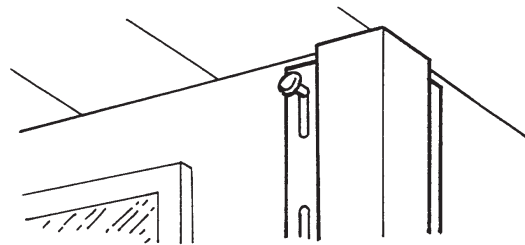

Figure 46.

**Note:** Install vinyl soffit and fascia before installing outside and inside corner posts.

### Bottom Receiver

- Position the top edge of a J-channel or vertical base (head flashing) along the previously snapped chalkline. Remember to drill 1/4" weepholes every 24".
- Fasten every 8" to 12". Use the center of the nail slots. All vinyl should be fastened securely but not tightly. Sideways movement should not be restricted. Leave 1/4" gaps at the corner posts (Fig. 47). Where lengths adjoin, trim the nailing flange 1" and overlap 1/2" to produce a neat joint (Fig. 48).

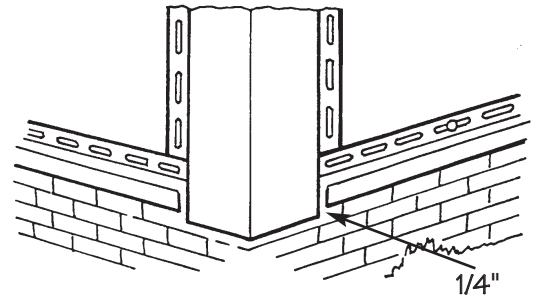

Figure 47.

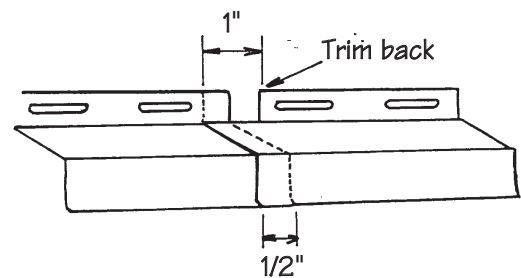

Figure 48.

### Window, Door, and Roof Trim

Install J-channel at the tops of the sidewalls. At the gable ends, snap a level chalkline along the base of the gable and install J-channel. Overlap where necessary and allow for expansion (Fig. 49).

After installing flashing, trim around all windows and doors using J-channel. The following sequence is suggested:

- Cut a J-channel for the bottom of the window, as wide as the frame, and install it.
- Cut side J-channels the length of the frame plus the width of the top and bottom J-channel. Cut and bend tabs (Fig. 50) into the bottom channel. Install the side channels.

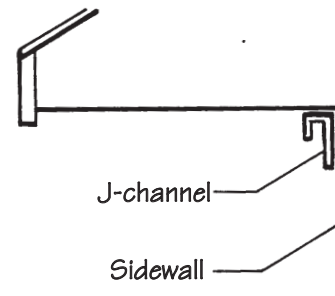

Figure 49.

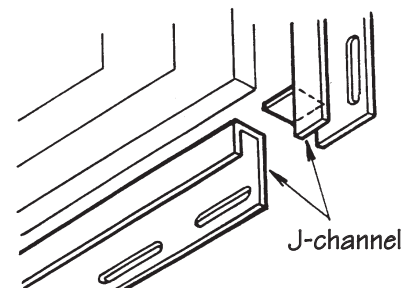
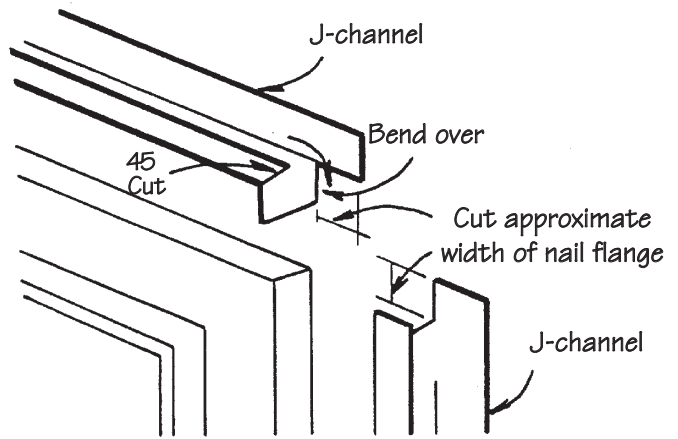

Figure 50.

- Cut the top J-channel the width of the frame PLUS the width of the side J-channels. Notch the top J-channel on each end, bend the tabs into the side J-channel, and fasten the top J-channel (Fig. 51).



- A miter cut and tab can be provided at the bottom of the window (see page 20), depending on the sill's condition.

Figure 51.

## Sidewalls

### Starter Strip

- Create a vertical starter strip by cutting the nailing hem and adjacent lock off a vertical siding panel. Fasten it inside the receiver channel of the corner post. Be sure this piece is plumb. Leave enough clearance in the pocket of the corner post to allow the siding panel to be attached (Fig. 52).

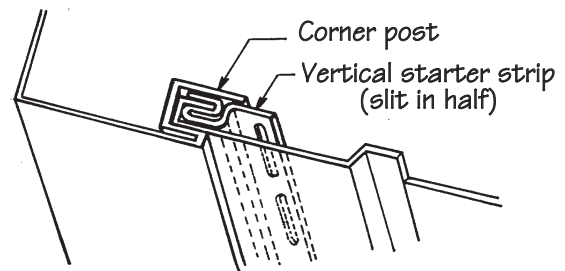

Figure 52.

- Install J-channels at top and bottom. Fasten panels 12" on center. Leave 1/4" clearance at top and 3/8" at bottom. Place the first fasteners in the uppermost end of the top nail slots to hold them in position. Place all other fasteners in the center of the slots.
- If it will take more than one course to span the height of the house, terminate the first course into an inverted J-channel (Fig. 53), allowing 1/4" for expansion. Install head flashing on top of the J-channel and begin the second course leaving 1/4" gap at the head flashing.

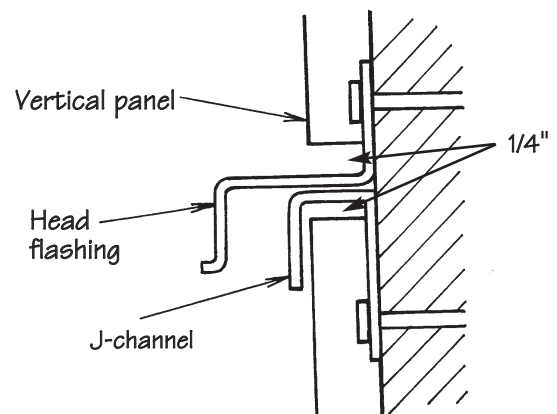

Figure 53.

## Panels

- Working from the starter strip to the corners, lock each panel and fasten every 12". Vertical panels are terminated into the J-channel installed at top and the vertical base or J-channel installed at bottom.

## Optional Method for Gable End Sidewalls

- Find the center of each sidewall and use a level or plumbline to install two back-to-back J-channels or an H-divider bar (Fig. 54). Leave a 1/4" gap at the top and bottom. These will serve as starter strips in which to lock the vertical siding.

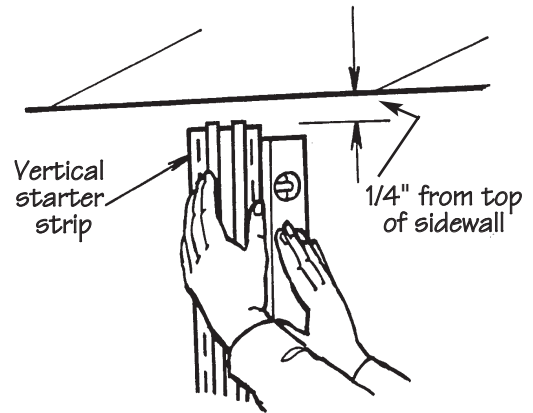

Figure 54.

## Windows and Doors

- At window and doors, cut the panels (if necessary) to fit the openings, allowing 1/4" for expansion.
- If the panel is uncut or cut down in the "V"-shaped groove of a piece of vertical siding, simply insert it into the J-channel, locking the other side onto the previously applied panel (Fig. 55). A furring strip should be installed to prevent panel detachment.
- If the panel is cut on the flat surface, install utility trim, backed by furring, into the J-channel. The flat surface of the vertical siding should be snap lock punched and fitted into the utility trim (Fig. 56). The panel is further secured above and below the windows and above the door when the panel is fastened in place.

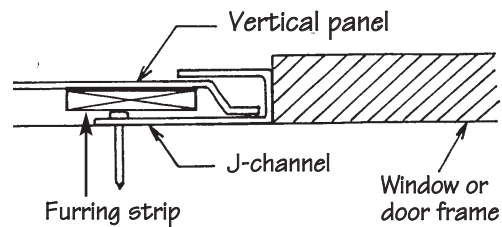

Figure 55.

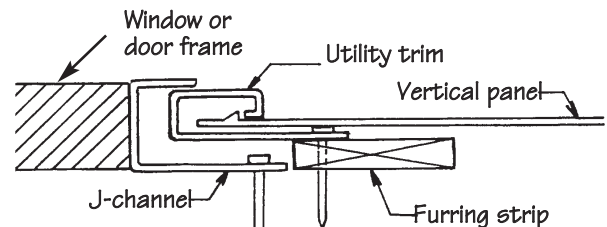

Figure 56.

## Corners

At corners, the following steps are recommended:

- Install the utility trim or J-channel into the receiver of the corner post.

- If the panel is cut in the bottom of the V-groove, insert it into the J-channel. A furring strip should be provided prior to panel insertion. This will prevent the panel from detaching (Fig. 57).
- If the panel is cut on the flat surface, install utility trim, backed by furring, into the J-channel. Punch snap locks along the cut edge of the panel at 6" intervals and snap it into the utility trim (Fig. 58).

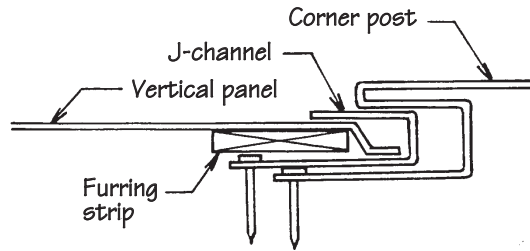

Figure 57.

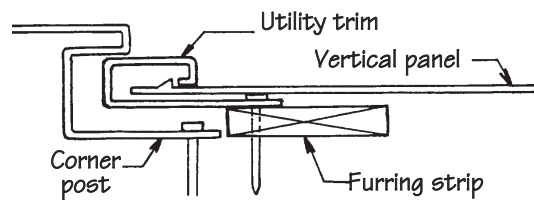

Figure 58.

### Gable Ends

For application of vertical siding to gables, follow the instructions below.

- Begin by fastening J-channel along the inside edge of the roof. Install vertical base (head flashing) on top of previously installed J-channel at the base of the gable.
- Attach either vertical siding starter strip or two back-to-back regular starter strips, centered with the peak of the gable (Fig. 59). This area should be flashed prior to installing the starter strips.
- Make a pattern for end cuts along the gable using two pieces of scrap siding (Fig. 60). Lock one piece into the vertical strip at the center of the wall. Hold the edge of the other piece against and in line with the roof line. Mark the slope on the vertical piece and cut along that line. Use it as a pattern to mark and cut the ends of all other panels required for this side of the gable. Make another pattern for the other side of the gable.

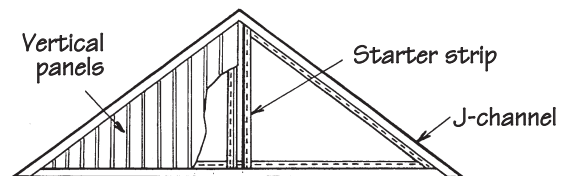

Figure 59.

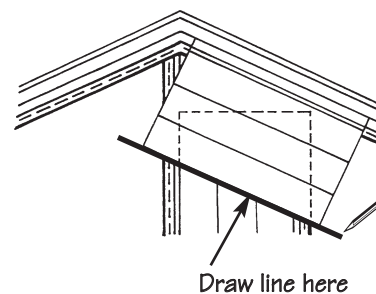

Figure 60.

## SOFFIT INSTALLATION

Soffit is the name given to materials used to enclose the underside of an eave. The installation of soffit will determine the positioning of the inside and outside corner posts. It also is necessary to complete the soffit before the final course of siding is installed on the wall.

**NOTE:** *Ventilation Requirements: Proper attic ventilation is important for any home. Consult a local building official for the appropriate requirements for a specific geographical area, and use vented soffit or other vented products as necessary.*

Vinyl soffit is designed to be easily installed lengthwise from wall to fascia (see Fig. 67). Soffit panels are similar to vertical siding. Manufacturers produce both solid and vented panels.

### Preparation

Inspect and plan the job in advance. For residing applications, nail down any loose panels, boards, or shingles. Check surfaces for straightness and furring when necessary. Surfaces should be uniform and straight from various viewing angles.

The procedure used to install soffit depends on the construction of the eave. There are two different types of eaves:

- Open eaves—eaves with exposed rafters or trusses—are typical of new construction. Open eave installation procedures are also used when removing damaged soffit during a residing project.
- Enclosed eaves—eaves with soffit in place—are typical of residing projects.



## Installation Over Open Eaves

Follow this 5-step procedure:

1. Install receiving channels (soffit receiver or J-channel).
  - There are several ways to install receiving channels for soffit. You can use accessories such as the J-channel or the F-channel. The best approach is to select a method that works most effectively with the construction techniques used to create the eave.
  - Examine the illustrations at right and find one that most closely resembles the construction methods used on this particular project (Fig. 61 through 64).
  - Install the receiving channels following the details shown in the illustrations. Nail channels every 12" to 16", positioning the nail in the center of the slot. Do not nail tightly.

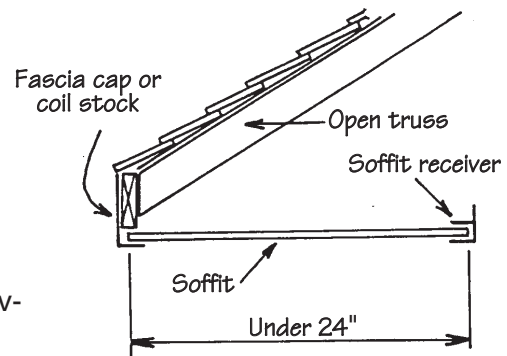

Figure 61.

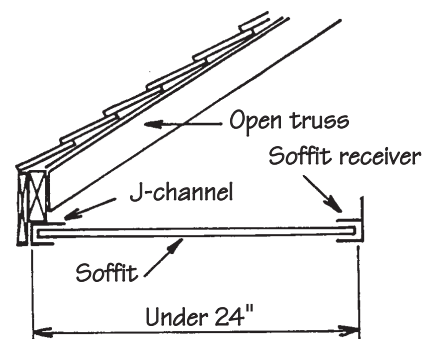

Figure 62.

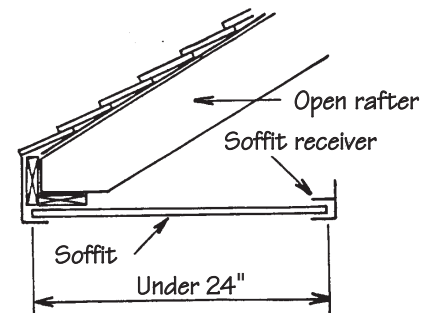

Figure 63.

**NOTE:** If the eave span is 24" or more, nailing strips must be installed as shown (Fig. 64). In areas with high wind restrictions, nailing should not exceed 12" on center.

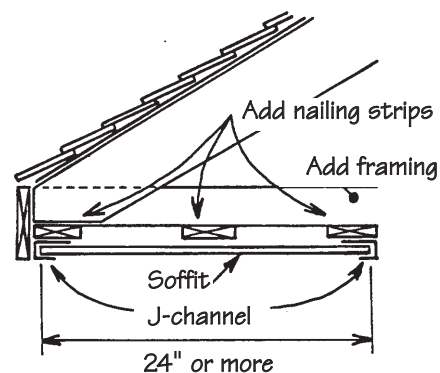

Figure 64.

- If no soffit receiver is available for a situation best suited for the product, the J-channel can be modified to create an F-receiver (Fig. 65).

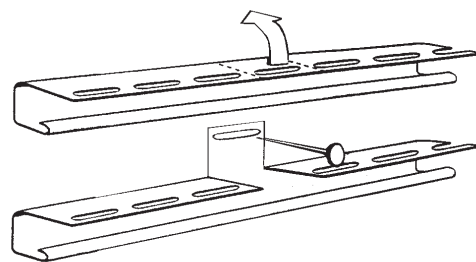

Figure 65.

- Simply cut slots in the nail flange area where it would be nailed to the wall (Fig. 65). After cutting the nail flange, bend the flange back and nail it to the wall.
- If the soffit will turn a corner, cut and install the channel so there is 1/4" for expansion at each of the adjoining walls.

2. Measure from the wall to the fascia board. Then subtract 1/2" to allow for expansion. Mark this dimension on a soffit panel and cross cut using a circular power saw with a reversed finetooth blade. Cut one or two panels at a time, carefully advancing the saw through the vinyl.
3. Insert the panel into the channel on the wall, then into the channel at the fascia board (Fig. 66).

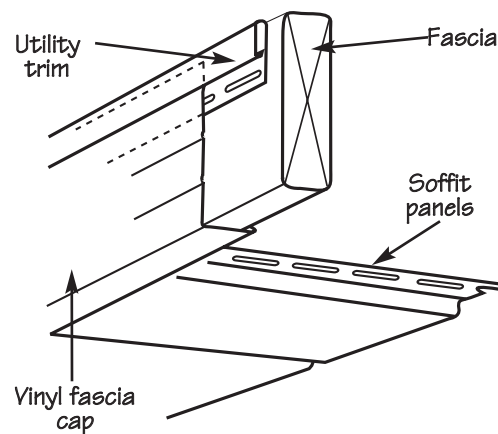

Figure 66.

- It might be necessary to flex the panel slightly to insert it into the second channel.
- Make certain the panel is perpendicular to the wall, then nail. Depending on the installation method being used, nails will be hammered either into a nailing strip or a fascia board.
- When using a nailing strip, do not nail tightly—allow movement for expansion. Continue the installation by locking and nailing the panels. Make certain the panels are fully locked along their entire length.

**NOTE:** When nailing to the fascia board, use small-headed nails. Drive the nail through the nail flange and "V"-shaped groove within the soffit panel. This is one of the rare instances that face nailing is permissible. Once a soffit panel is face-nailed, it will expand only in one direction, in this case, toward the receiving channel. Be sure to leave space for the full expansion allowance in the receiving channel.

4. To turn a corner, measure from the channel at the wall corner to the channel at the corner of the fascia board (Fig. 67). Subtract 1/4" for expansion. Cut and install soffit double channel lineal or back-to-back J-channel. If necessary, install nailing strips to provide backing for the lineal. Miter cut the corner soffit panels and install as described in Step 3.
5. To complete the installation, apply the utility trim and fasten the aluminum fascia cap or formed aluminum coil stock with painted trim nails. If necessary to face nail fascia, drill holes for the trim nails to allow for expansion and to reduce denting of the aluminum.

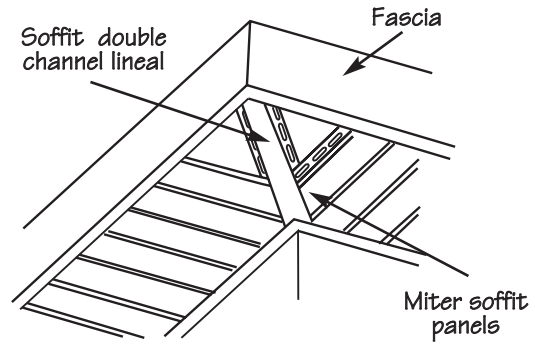

Figure 67.

### Installation Over Enclosed Eaves

The procedure used to install soffit over an enclosed eave is almost identical to that used for an open eave. The major difference is the installation of the J-channel (Fig. 68 and 69).

- Determine the preferred method of installing soffit at the fascia board.

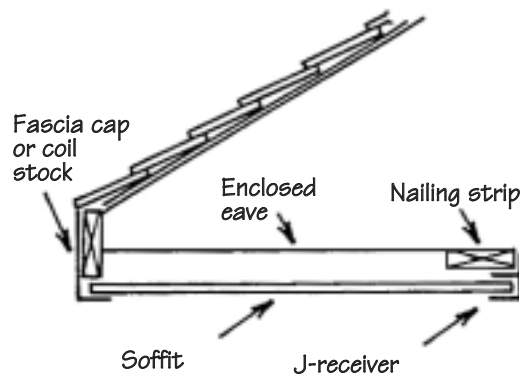

Figure 68.

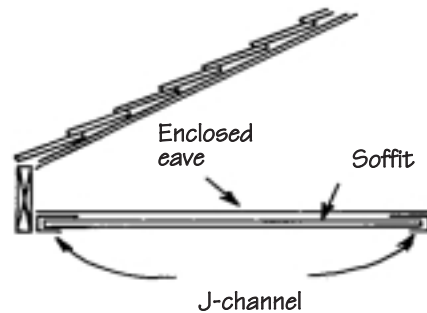

Figure 69.

**NOTE:** If the existing soffit is rotted or damaged, remove it completely before installing vinyl soffit, then use the instructions for open eaves.

- When installing J-channel at either wall of fascia board, nail every 12" to 16".
- If the soffit is to turn a corner, cut and install J-channel to allow 1/4" for expansion at each of the adjoining walls and fascia boards.
- When installing vented soffit panels, if the existing soffit doesn't have openings for ventilation, cut an adequate number of openings.
- To complete the installation, follow Steps 3 through 5 from "Installation Over Open Eaves."

## Porch Ceilings

The procedures used to install a porch ceiling are in many ways similar to those used to install soffit. These procedures vary slightly, depending on whether the installation is a new construction or a residing project.

### New Construction Projects

1. Begin by installing receiving channels on all four sides of the porch (Fig. 70). If F-receivers are being used, nail them to the existing walls. If J-channels are being used, a nailing base will have to be installed.
2. When planning to use light blocks to attach external light fixtures, install them to adequate backing.
3. Plan the layout of the ceiling panels to achieve an even balance or to align with adjacent work. If the ceiling panels will run parallel to the ceiling joists, additional 1" x 3" wood furring nailing strips will have to be installed. Install these nailing strips perpendicular to the ceiling joists, placing a strip every 12" to 16".
4. Invert the J-channels and nail them to the underside of the wood strips along the perimeter of the ceiling area.
5. Install the first panel into the channels at one end of the porch. Be sure to leave room for expansion. Nail every 12" to 16", positioning nails in the centers of slots. Do not nail tightly. Install the remaining panels. When cutting the last panel of the first course, be sure to allow room for expansion.
6. For areas where more than one panel length is needed, use a double channel lineal or back-to-back J-channel.

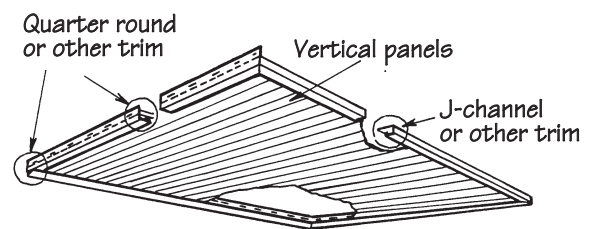

Figure 70.

7. If it is necessary to cut the nailing hem off the final panel, use a snap lock punch to create tabs every 8" to 10" along the cut edge. Attach utility trim and insert the panel into the receiving channel.

### Residing Projects

1. Check to be sure the existing ceiling can serve as a solid nailing base.
2. If the existing ceiling is solid, remove all existing moldings and fixtures from the ceiling and begin by nailing inverted J-channels along the perimeter of the ceiling area. Then follow Steps 2 through 6 in the instructions under "New Construction." With a solid ceiling, however, additional nailing strips are not necessary. Use the existing ceiling as the nailing base for the panels.
3. If the existing ceiling is not solid, install nailing strips to provide a secure nailing base, then install the J-channels. Additional nailing strips should be installed if the ceiling panels are to run parallel to the ceiling joists. Follow the instructions in Steps 2 through 6 for new construction.

## OTHER RECOMMENDATIONS

### Replacing a Damaged Panel

To remove a panel for any reason:

- Slip the unlocking tool behind the bottom of the panel above the one to be replaced and unzip it from the lock on the damaged panel (Fig. 71).

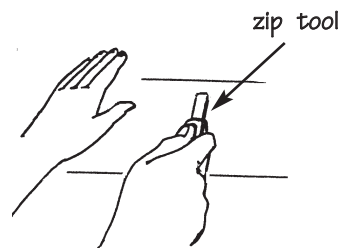

Figure 71.

- Gently bend out the upper panel. Take the nails out of the damaged panel and remove it (Fig. 72).

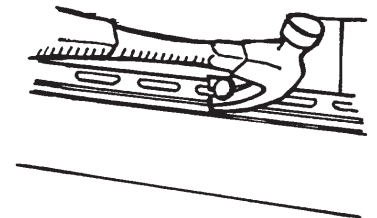

Figure 72.

- Lock on the new panel and nail it up (Fig. 73).

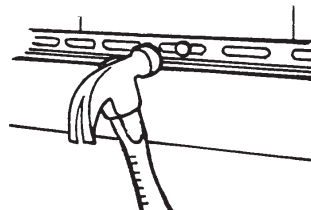

Figure 73.

- Use the unlocking tool again to zip the upper panel over the lock on the new panel (Fig. 74).

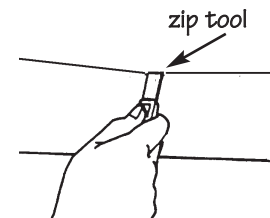

Figure 74.

## Residing Over Asbestos Siding

Asbestos siding is a regulated material, and the appropriate environmental agency should be contacted before residing over this product begins.

### Capping a Corner Post

- Corner posts on homes with a second-story overhang need to be capped by making the cuts shown (Fig. 75). Fold the flaps created over each other as indicated.
- Drill a 1/8" hole in the center, through both layers of vinyl, and install a pop rivet to hold them in place. Cut a notch in both layers to allow clearance for the corner (Fig. 76).

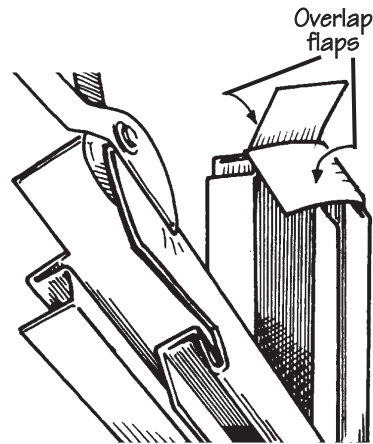

Figure 75.

### Repairing a Damaged Corner Post

Repair a damaged corner post with a series of cuts:

- Cut away the face of the damaged corner, leaving the nail hem intact.
- Remove the nail hem from the replacement corner and trim it to fit.
- Place the new corner over the nailing hem of the old and fasten it into position.

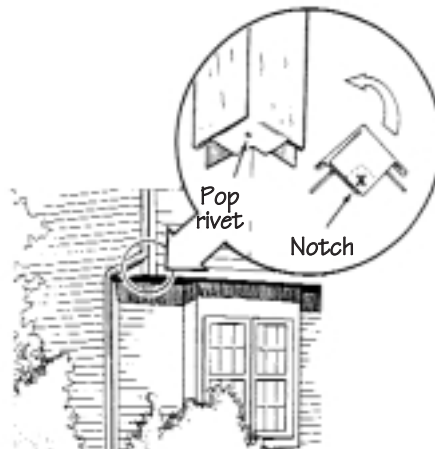

Figure 76.

## Historic Restoration

When possible historic restoration issues arise, VSI recommends the following:

- If a building is in a historic area, local Historic District, or has been designated as a historic building, make sure that approval for the use of vinyl siding has been obtained from the local historic society or local Historic District Commission. This applies to building additions as well.
- Before a historic building is resided, it should be examined for moisture, insect infestation, structural defects, and other problems that may be present. These problems should be addressed and the building pronounced “healthy” before residing with any material.
- Do not damage or remove the original siding. If at all possible, do not alter the original structure, so that the application of vinyl siding is reversible (i.e., the original siding would remain intact in the future, so that if desired, the vinyl siding could be removed). Exception: “In cases where a nonhistoric artificial siding has been applied to the building, the removal of such a siding before application of vinyl siding would, in most cases, be acceptable.” (*Preservation Briefs*, Number 8, U.S. Department of Interior, 1984.)<sup>1</sup>
- Exercise every care to retain architectural details wherever possible. Do not remove, cover, or add details until the building owners’ written approval has been obtained. Determine that the owner has consulted the local historic society for approval.
- Use siding that closely approximates the appearance of the original siding in color, size, and style. In historic districts, the goal is to match the product as closely as possible and retain the original trim.

<sup>1</sup>*Preservation Briefs*, Number 8, can be ordered by contacting the Superintendent of Documents at 202 512-1800. Or, the brief can be viewed via the Heritage Preservation Web Site at [www2.cr.nps.gov/](http://www2.cr.nps.gov/). GPO stock number: 024-005-01026-2



VINYL SIDING INSTITUTE



THE SOCIETY OF THE PLASTICS INDUSTRY, INC.

1801 K Street, NW  
Suite 600K  
Washington, DC 20006

For more information,  
visit VSI's web site  
<[www.vinylsiding.org](http://www.vinylsiding.org)>  
or contact the  
Vinyl Siding Information Center  
1-888-FOR-VSI-1

