

SELF-CONTAINED



12 SEER SELF-CONTAINED AIR CONDITIONERS

RSMA- SERIES



Nominal Sizes 1 1/2 to 4 Tons
[5 to 14 kW]

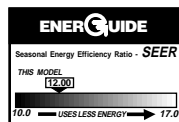

*CERTIFIED UNDER THE
A.R.I. CERTIFICATION
PROGRAM—A.R.I.
STANDARD 210*

ENGINEERING FEATURES

RSMA- Series Self-Contained Air Conditioners

1. All models feature Copeland® Compliant Scroll® compressors for maximum efficiency and quiet operation.
2. Louvered condenser compartment for protecting the coil against yard hazards and/or weather extremes.
3. One-piece top with a drip lip to help keep water off of the unit sides.
4. Supply and return air openings feature a one-inch tall flange to prevent water migration into the ductwork.
5. Access panels have “weep holes” and channels to further help manage water run-off.
6. Side and down discharge options available on all models.
7. Easily accessible blower section complete with slide-out blower. All units feature a system matched MultiFlex® coil with low static pressure drop and excellent cooling capacities.
8. Refrigerant connections are conveniently located for easy service diagnostics.
9. Condenser and evaporator coils feature enhanced fins for better heat transfer and rifled copper tubing for greater efficiency.
10. Supplemental electric heat strips up to 15 kW are available (field or factory installed) for periods of extreme cold temperatures. Single point wiring makes installation even easier.
11. All units feature an internal trap on the condensate line eliminating the need for installing an on-site external trap.
12. Integral gasketing on the base rails is standard on those units shipped from the factory in the down-flow configuration.
13. Easily accessible control box.

MODEL IDENTIFICATION

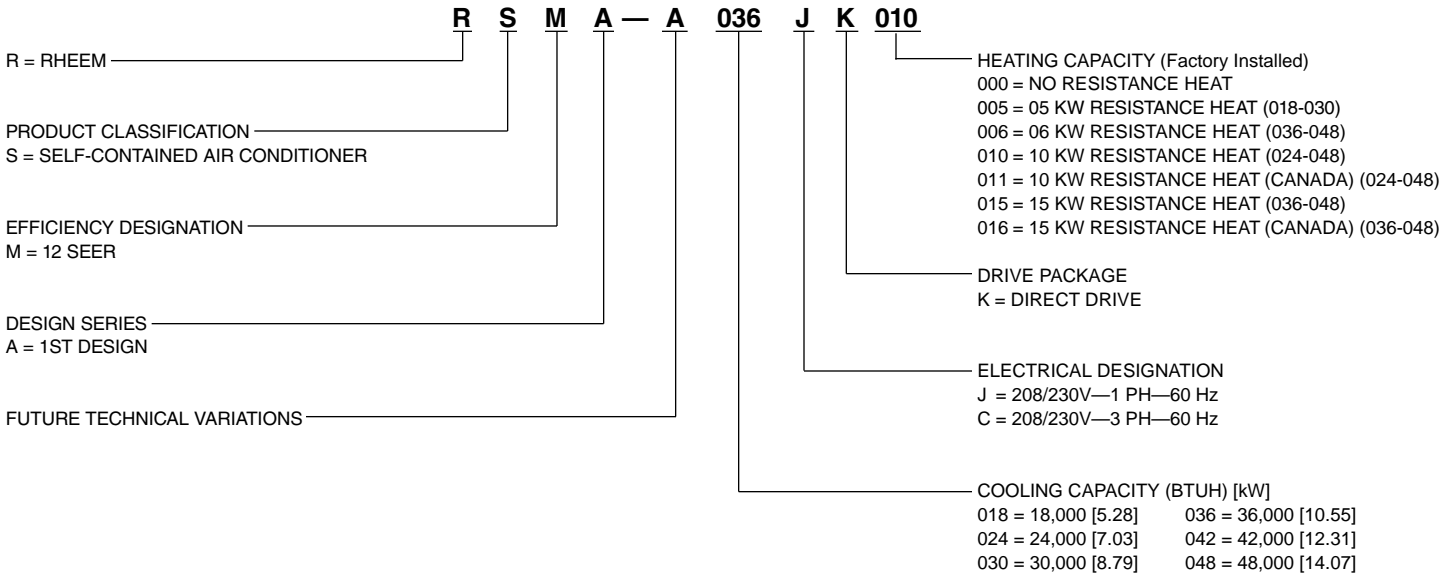

[] Designates Metric Conversions

These quality features are included in the Rheem Self-Contained Outdoor Air Conditioning Unit

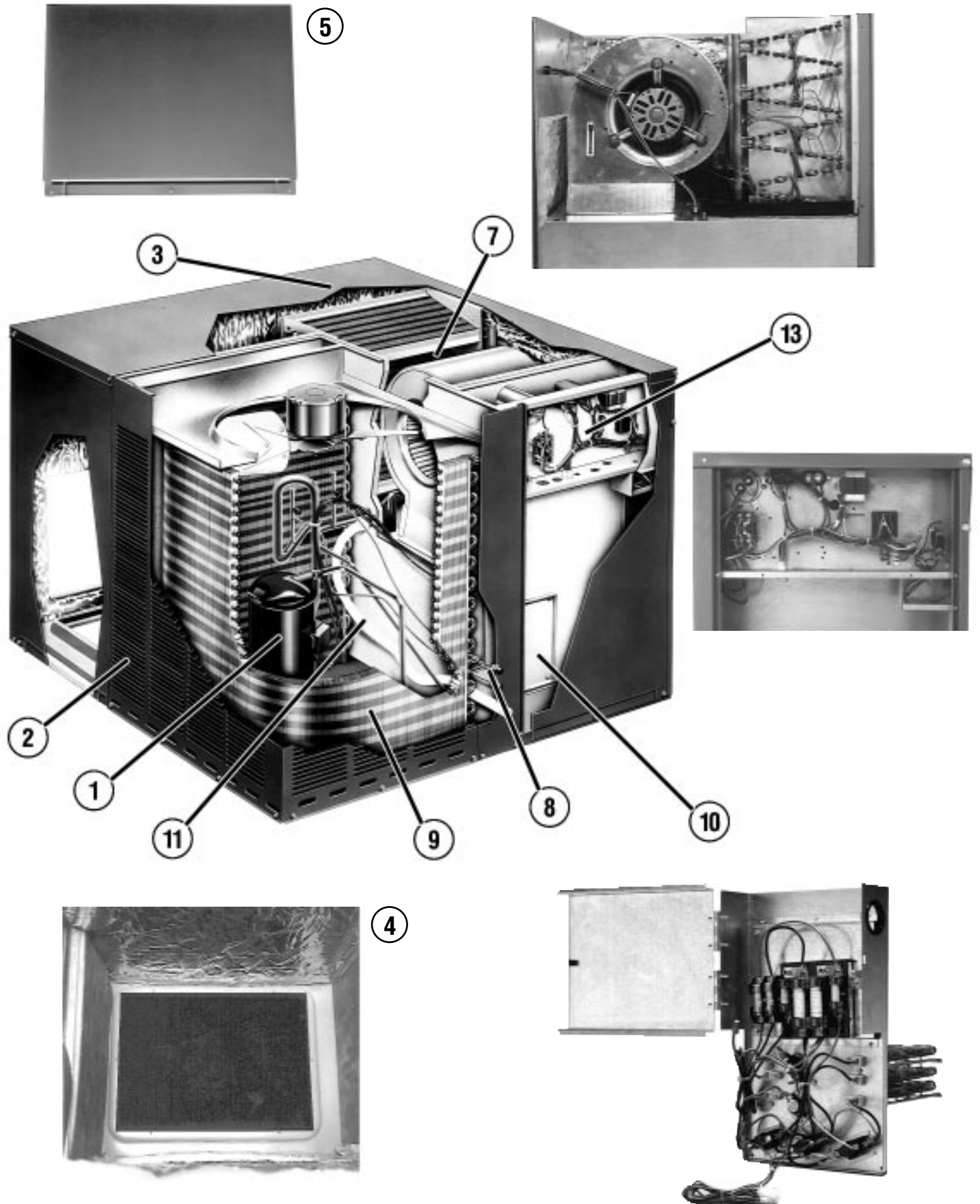

ACCESSORY EQUIPMENT

Accessory Description	Model Application	Accessory Model No.
Roofcurbs	RSMA	RXSG-AAA08 (8" [203 mm] Height) RXSG-AAA14 (14" [356 mm] Height) RXSG-AAA24 (24" [610 mm] Height)
Supply & Return Diffusers	RSMA	RXRN-BD15
Economizers (Downflow Only)	RSMA	RXRE-CAA30 (3 Position) RXRD-CAM10 (Fully Modulating)
Fresh Air Damper	RSMA	RXRF-FAB1 (Motorized-35%) RXRF-FAA1 (Fixed-35%)
Rectangular to Round Transition (Downflow)	RSMA	RXMC-CA02 (16" [406 mm] Ducts) RXMC-CA03 (18" [457 mm] Ducts)
Filter Kit	RSMA	RXRY-B01
Low Ambient Control	RSMA	RXRZ-A18
High Pressure Control	RSMA	RXAB-A02
Low Pressure Control	RSMA	RXAC-A02
Rectangular to Round Transition—Sideflow (Mobile Home)	RSMA	RXMC-BA01

[] Designates Metric Conversions

ROOFCURB ADAPTERS

See accessory specification sheet Form No. X11-1137 for retrofit applications.

RXPX-BACCA20	RXPX-BACCA22
RXRX-BACDB20	RXRX-BACDB22
RXPX-BACCA21	RXPX-BACCA23
RXRX-BACDB21	RXRX-BACDB23

COPELAND® COMPLIANT SCROLL® COMPRESSOR

All of our package units—regardless of efficiency level—feature the Copeland Compliant Scroll Compressor. The scroll compressor uses a more advanced technology than traditional reciprocating compressors. They have fewer moving parts, and they are quieter, more efficient, and longer lasting.



BEFORE PURCHASING THIS APPLIANCE, READ IMPORTANT ENERGY COST AND EFFICIENCY INFORMATION AVAILABLE FROM YOUR RETAILER.

GENERAL TERMS OF LIMITED WARRANTY*

Rheem will furnish a replacement for any part of this product which fails in normal use and service within the applicable periods stated, in accordance with the terms of the limited warranty.

Condenser Coil and Evaporator Coil leaks caused by factory defects.....	Five (5) Years
Compressor (1 Phase).....	Ten (10) Years
Compressor (3 Phase).....	Five (5) Years
Any Other Part.....	One (1) Year

*For Complete Details of the Limited Warranty, Including Applicable Terms and Conditions, See Your Local Installer or Contact the Manufacturer for a Copy.

ELECTRIC HEATER KITS—RSMA

Unit Model Application	Electric Heater Kit Models	Country
RSMA-A018JK	RXQJ-A03J (208/240 volt, 1-ph, 3kW)	USA & Canada
	RXQJ-A05J (208/240 volt, 1-ph, 5kW)	USA & Canada
	RXQJ-A06J (208/240 volt, 1-ph, 6kW)	USA & Canada
	RXQJ-A08J (208/240 volt, 1-ph, 8kW)	USA & Canada
RSMA-A024JK	RXQJ-A03J (208/240 volt, 1-ph, 3kW)	USA & Canada
	RXQJ-A05J (208/240 volt, 1-ph, 5kW)	USA & Canada
	RXQJ-A06J (208/240 volt, 1-ph, 6kW)	USA & Canada
	RXQJ-A08J (208/240 volt, 1-ph, 8kW)	USA & Canada
	RXQJ-A10J (208/240 volt, 1-ph, 10kW)	USA Only
	RXQJ-A11J (208/240 volt, 1-ph, 10kW-Canadian)	USA & Canada
RSMA-A030JK	RXQJ-A03J (208/240 volt, 1-ph, 3kW)	USA & Canada
	RXQJ-A05J (208/240 volt, 1-ph, 5kW)	USA & Canada
	RXQJ-A06J (208/240 volt, 1-ph, 6kW)	USA & Canada
	RXQJ-A08J (208/240 volt, 1-ph, 8kW)	USA & Canada
	RXQJ-A10J (208/240 volt, 1-ph, 10kW)	USA Only
	RXQJ-A11J (208/240 volt, 1-ph, 10kW-Canadian)	USA & Canada
RSMA-A036JK	RXQJ-A06J (208/240 volt, 1-ph, 6kW)	USA & Canada
	RXQJ-A08J (208/240 volt, 1-ph, 8kW)	USA & Canada
	RXQJ-A10J (208/240 volt, 1-ph, 10kW)	USA Only
	RXQJ-A11J (208/240 volt, 1-ph, 10kW-Canadian)	USA & Canada
	RXQJ-A15J (208/240 volt, 1-ph, 15kW)	USA Only
	RXQJ-A16J (208/240 volt, 1-ph, 15kW-Canadian)	USA & Canada
RSMA-A042JK	RXQJ-A06J (208/240 volt, 1-ph, 6kW)	USA & Canada
	RXQJ-A08J (208/240 volt, 1-ph, 8kW)	USA & Canada
	RXQJ-A10J (208/240 volt, 1-ph, 10kW)	USA Only
	RXQJ-A11J (208/240 volt, 1-ph, 10kW-Canadian)	USA & Canada
	RXQJ-A15J (208/240 volt, 1-ph, 15kW)	USA Only
	RXQJ-A16J (208/240 volt, 1-ph, 15kW-Canadian)	USA & Canada
RSMA-A048JK	RXQJ-A06J (208/240 volt, 1-ph, 6kW)	USA & Canada
	RXQJ-A08J (208/240 volt, 1-ph, 8kW)	USA & Canada
	RXQJ-B10J (208/240 volt, 1-ph, 10kW)	USA Only
	RXQJ-B11J (208/240 volt, 1-ph, 10kW-Canadian)	USA & Canada
	RXQJ-B15J (208/240 volt, 1-ph, 15kW)	USA Only
	RXQJ-B16J (208/240 volt, 1-ph, 15kW-Canadian)	USA & Canada
RSMA-A036CK	RXQJ-A10C (208/240 volt, 3-ph, 10kW)	USA & Canada
	RXQJ-A12C (208/240 volt, 3-ph, 12kW)	USA Only
	RXQJ-A15C (208/240 volt, 3-ph, 15kW)	USA Only
	RXQJ-A16C (208/240 volt, 3-ph, 15kW-Canadian)	USA & Canada
RSMA-A042CK	RXQJ-A10C (208/240 volt, 3-ph, 10kW)	USA & Canada
	RXQJ-A12C (208/240 volt, 3-ph, 12kW)	USA Only
	RXQJ-A15C (208/240 volt, 3-ph, 15kW)	USA Only
	RXQJ-A16C (208/240 volt, 3-ph, 15kW-Canadian)	USA & Canada
RSMA-A048CK	RXQJ-A10C (208/240 volt, 3-ph, 10kW)	USA & Canada
	RXQJ-A12C (208/240 volt, 3-ph, 12kW)	USA Only
	RXQJ-A15C (208/240 volt, 3-ph, 15kW)	USA Only
	RXQJ-A16C (208/240 volt, 3-ph, 15kW-Canadian)	USA & Canada

[] Designates Metric Conversions

WARNING
<p>ONLY ELECTRIC HEATER KITS SUPPLIED BY THIS MANUFACTURER AS DESCRIBED IN THIS PUBLICATION HAVE BEEN DESIGNED, TESTED, AND EVALUATED BY A NATIONALLY RECOGNIZED SAFETY TESTING AGENCY FOR USE WITH THIS UNIT. USE OF ANY OTHER MANUFACTURED ELECTRIC HEATERS INSTALLED WITHIN THIS UNIT MAY CAUSE HAZARDOUS CONDITIONS RESULTING IN PROPERTY DAMAGE, FIRE, BODILY INJURY OR DEATH.</p>

PERFORMANCE DATA— SELF-CONTAINED AIR CONDITIONER—12 SEER

Model No. RSMA-	ARI Cooling Performance						
	Cooling Capacity Indoor Air 80°F [26.5°C] DB/67°F [19.5°C] WB Outdoor Air 95°F [35.0°C] DB Design Conditions						
	Total Capacity BTU/H [kW]	Net Sens. BTU/H [kW]	Net Latent BTU/H [kW]	EER ①	SEER	Sound Rating ②	Indoor CFM [L/s]
A018JK	18,000 [5.28]	12,712 [3.72]	5,288 [1.56]	10.70	12.00	7.6	600 [285]
A024JK	24,000 [7.02]	17,104 [5.01]	6,896 [2.01]	10.40	12.00	7.6	800 [380]
A030JK	28,600 [8.40]	20,306 [5.94]	8,294 [2.46]	10.30	12.00	7.6	1000 [470]
A036CK/JK	35,800 [10.50]	24,100 [7.08]	11,700 [3.42]	10.60	12.00	7.6	1200 [585]
A042CK/JK	40,000 [11.70]	28,312 [8.28]	11,688 [3.42]	10.35	12.00	7.6	1400 [660]
A048CK/JK	46,000 [13.50]	32,325 [9.48]	13,675 [4.02]	10.30	12.00	7.8	1500 [710]

① EER data is generated independent of an ARI certification program.

② Sound rating in accordance with ARI Standard 270.

ELECTRICAL AND PHYSICAL DATA—SELF-CONTAINED AIR CONDITIONER—12 SEER

Model No. RSMA-	ELECTRICAL								PHYSICAL									
	Phase Frequency (Hz) Voltage (Volts)	Compressor		Full Load Amperes (FLA)		Minimum Circuit Ampacity Amperes	Fuse or HACR Circuit Breaker		Drive Type	Cond. Motor HP [W]	Blower Motor HP [W]	Filter Recommended No. and Size [mm x mm x mm]	Outdoor Coil			R22 Oz. [g]	Weight	
		Rated Load Amperes (RLA)	Locked Rotor Amperes (LRA)	Fan Motor	Blower Motor		Minimum Amperes	Maximum Amperes					Area Sq. Ft. [Sq. m]	No. Rows	CFM [L/s]		Net Lbs. [kg]	Ship Lbs. [kg]
A018JK	1-60-208/230	9.6/9.6	50	.5	1.3	14/14	20/20	20/20	Direct	1/15 [50]	1/4 [186]	(1) 1 x 16.0 x 20.0 [25 x 406 x 508]	12.8 [1.189]	1.00	1815 [857]	69 [1956]	334 [151.5]	374 [169.6]
A024JK	1-60-208/230	12.2/12.2	61.7	.5	1.3	17/17	25/25	25/25	Direct	1/15 [50]	1/4 [186]	(1) 1 x 20.0 x 20.0 [25 x 508 x 508]	12.8 [1.189]	1.00	1815 [857]	70 [1984]	344 [156.0]	384 [174.2]
A030JK	1-60-208/230	13.5/13.5	72.5	1.3	2.4	21/21	25/25	30/30	Direct	1/5 [149]	1/2 [373]	(1) 1 x 24.0 x 24.0 [25 x 610 x 610]	12.8 [1.189]	1.00	2675 [1262]	80 [2268]	363 [164.7]	403 [182.8]
A036CK	3-60-208/230	10.3/10.3	77	1.3	2.4	17/17	20/20	25/25	Direct	1/5 [149]	1/2 [373]	(1) 1 x 24.0 x 24.0 [25 x 610 x 610]	12.8 [1.189]	2.00	2500 [1180]	99 [2807]	385 [174.6]	425 [192.8]
A036JK	1-60-208/230	16.5/16.5	95	1.3	2.4	25/25	30/30	40/40	Direct	1/5 [149]	1/2 [373]	(1) 1 x 24.0 x 24.0 [25 x 610 x 610]	12.8 [1.189]	2.00	2500 [1180]	99 [2807]	385 [174.6]	425 [192.8]
A042CK	3-60-208/230	12.5/12.5	88	1.3	2.4	20/20	25/25	30/30	Direct	1/5 [149]	1/2 [373]	(1) 1 x 24.0 x 24.0 [25 x 610 x 610]	12.8 [1.189]	2.00	2500 [1180]	114 [3232]	389 [176.4]	429 [194.6]
A042JK	1-60-208/230	18.0/18.0	104	1.3	2.4	27/27	35/35	40/40	Direct	1/5 [149]	1/2 [373]	(1) 1 x 24.0 x 24.0 [25 x 610 x 610]	12.8 [1.189]	2.00	2500 [1180]	114 [3232]	389 [176.4]	429 [194.6]
A048CK	3-60-208/230	13.5/13.5	120	1.7	4.4	23/23	30/30	35/35	Direct	1/3 [249]	3/4 [559]	(1) 1 x 24.0 x 24.0 [25 x 610 x 610]	12.8 [1.189]	2.00	2900 [1369]	117 [3317]	425 [192.8]	465 [210.9]
A048JK	1-60-208/230	23.7/23.7	129	1.7	4.4	36/36	45/45	50/50	Direct	1/3 [249]	3/4 [559]	(1) 1 x 24.0 x 24.0 [25 x 610 x 610]	12.8 [1.189]	2.00	2900 [1369]	117 [3317]	434 [196.9]	474 [215.0]

[] Designates Metric Conversions

INDOOR AIRFLOW PERFORMANCE—230 VOLTS

Nominal Cooling Capacity Tons [kW]	Motor Speed from Factory	Blower Size/ Motor HP [W] & # of Speeds	Motor Speed	CFM [L/s] Air Delivery/RPM/Watts—230 Volts Side Discharge—Wet Coil							
				External Static Pressure—Inches W.C. [kPa]							
				0.1 [.02]	0.2 [.05]	0.3 [.07]	0.4 [.10]	0.5 [.12]	0.6 [.15]	0.7 [.17]	
1.5 [5.28]	Low	9 x 7 1/4 HP [186] 2 Speed Motor	Low	CFM	771 [364]	751 [354]	725 [342]	691 [326]	645 [304]	584 [276]	546 [258]
				RPM	825	870	910	950	985	1010	1030
				Watts	253	242	230	217	204	189	181
2.0 [7.03]	High		High	CFM	946 [446]	922 [435]	882 [416]	830 [392]	769 [363]	701 [331]	630 [298]
				RPM	990	1015	1035	1055	1070	1085	1100
				Watts	315	303	288	273	257	241	226
2.5 [8.79]	Low	10 x 9 1/2 HP [373] 3 Speed Motor	Low	CFM	1206 [569]	1182 [558]	1157 [546]	1128 [532]	1091 [515]	1044 [493]	983 [464]
				RPM	760	815	870	910	950	975	1000
				Watts	419	406	394	381	368	353	334
3.0 [10.55]	Med		Med	CFM	1411 [666]	1368 [646]	1327 [626]	1285 [606]	1238 [584]	1183 [558]	1116 [527]
				RPM	865	900	935	970	1000	1020	1035
				Watts	498	481	464	447	430	411	391
3.5 [12.31]	High		High	CFM	1641 [774]	1577 [744]	1515 [715]	1455 [687]	1393 [657]	1329 [627]	1262 [596]
				RPM	980	1000	1020	1035	1050	1065	1080
				Watts	589	565	543	523	503	481	456
4.0 [14.07]	Med	10 x 9 3/4 HP [559] 3 Speed Motor	Low	CFM	1390 [656]	1387 [655]	1375 [649]	1353 [639]	1319 [622]	1272 [600]	1210 [571]
				RPM	781	839	896	935	974	1003	1032
				Watts	431	459	486	512	536	558	579
			Med	CFM	1875 [885]	1806 [852]	1739 [821]	1672 [789]	1602 [756]	1528 [721]	1447 [683]
				RPM	1024	1042	1059	1073	1087	1098	1109
				Watts	736	690	653	620	590	559	523
			High	CFM	2024 [955]	1960 [925]	1882 [888]	1793 [846]	1698 [801]	1602 [756]	1509 [712]
				RPM	1089	1099	1108	1116	1124	1130	1136
				Watts	809	776	739	700	661	622	587

INDOOR AIRFLOW PERFORMANCE—208 VOLTS

1.5 [5.28]	Low	9 x 7 1/4 HP [186] 2 Speed Motor	Low	CFM	675 [319]	657 [310]	634 [299]	602 [284]	560 [264]	505 [238]	435 [205]
				RPM	695	785	870	905	940	980	1020
				Watts	221	214	203	191	171	163	149
2.0 [7.03]	High		High	CFM	898 [424]	861 [406]	822 [388]	777 [367]	721 [340]	651 [307]	562 [265]
				RPM	940	965	995	1020	1045	1070	1090
				Watts	292	278	266	253	239	221	199
2.5 [8.79]	Low	10 x 9 1/2 HP [373] 3 Speed Motor	Low	CFM	1076 [508]	1059 [500]	1032 [490]	996 [470]	950 [448]	896 [423]	832 [393]
				RPM	730	775	820	865	905	940	975
				Watts	356	349	341	331	320	305	287
3.0 [10.55]	Med		Med	CFM	1222 [577]	1197 [565]	1179 [556]	1162 [548]	1137 [537]	1097 [518]	1033 [488]
				RPM	765	810	855	890	920	960	995
				Watts	423	415	407	397	386	370	351
3.5 [12.31]	High		High	CFM	1514 [715]	1461 [670]	1415 [668]	1370 [647]	1322 [624]	1266 [597]	1197 [565]
				RPM	895	930	965	985	1005	1025	1045
				Watts	538	514	493	473	454	343	412
4.0 [14.07]	Med	10 x 9 3/4 HP [559] 3 Speed Motor	Low	CFM	1179 [556]	1180 [557]	1183 [558]	1181 [557]	1169 [552]	1139 [538]	1087 [513]
				RPM	684	755	825	873	921	960	999
				Watts	490	477	464	448	430	409	384
			Med	CFM	1719 [811]	1681 [793]	1634 [771]	1579 [745]	1516 [715]	1448 [683]	1373 [648]
				RPM	943	977	1011	1032	1052	1067	1082
				Watts	681	645	611	579	548	516	484
			High	CFM	1954 [922]	1888 [891]	1816 [857]	1737 [820]	1655 [781]	1570 [741]	1483 [700]
				RPM	1060	1075	1089	1098	1106	1115	1123
				Watts	769	731	692	654	617	583	551

NOTES: 1. Data reflects airflow with electric strip heat installed.

2. Do not operate unit in shaded regions (CFM greater than 1700 on 4 ton models) due to possibility of water blow-off.

[] Designates Metric Conversions

DOWN DISCHARGE PRESSURE DROP (ADD TO EXTERNAL STATIC PRESSURE)						
CFM [L/s]	600 [283]	800 [378]	1000 [472]	1200 [566]	1400 [661]	1600 [775]
Pressure Drop—Inches W.C. [kPa]	.00	.01 [.002]	.02 [.005]	.03 [.007]	.05 [.012]	.07 [.017]
MINIMUM RECOMMENDED FILTER SIZES						
Nominal Cooling Capacity Tons [kW]	1.5 [5.28]		2.0 [7.03]		2.5 [8.79] – 4.0 [14.07]	
Minimum Filter Size—Inches [mm]	16 x 20 x 1 [406 x 508 x 25]		20 x 20 x 1 [508 x 508 x 25]		24 x 24 x 1 [610 x 610 x 25]	

TYPICAL INSTALLATIONS

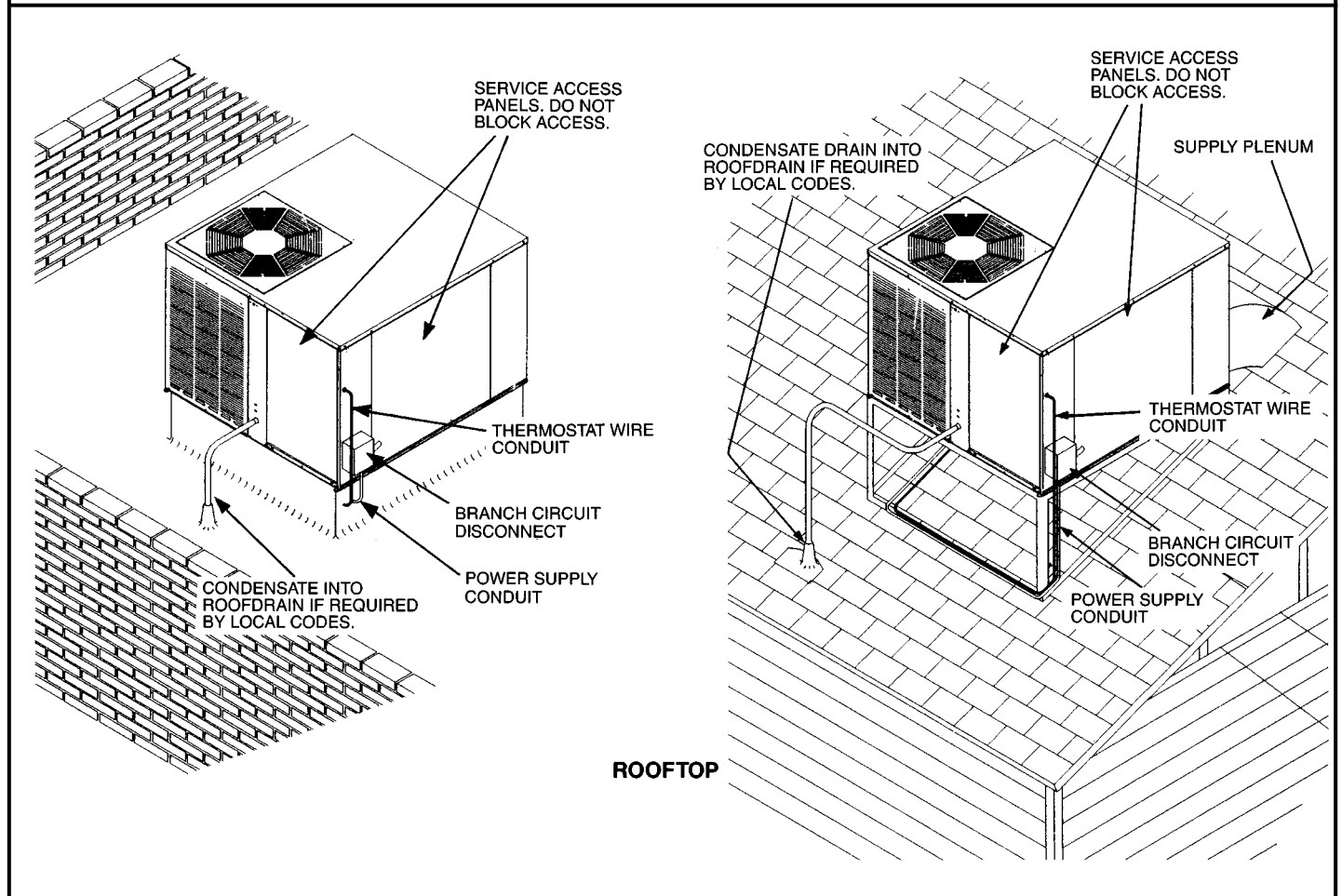
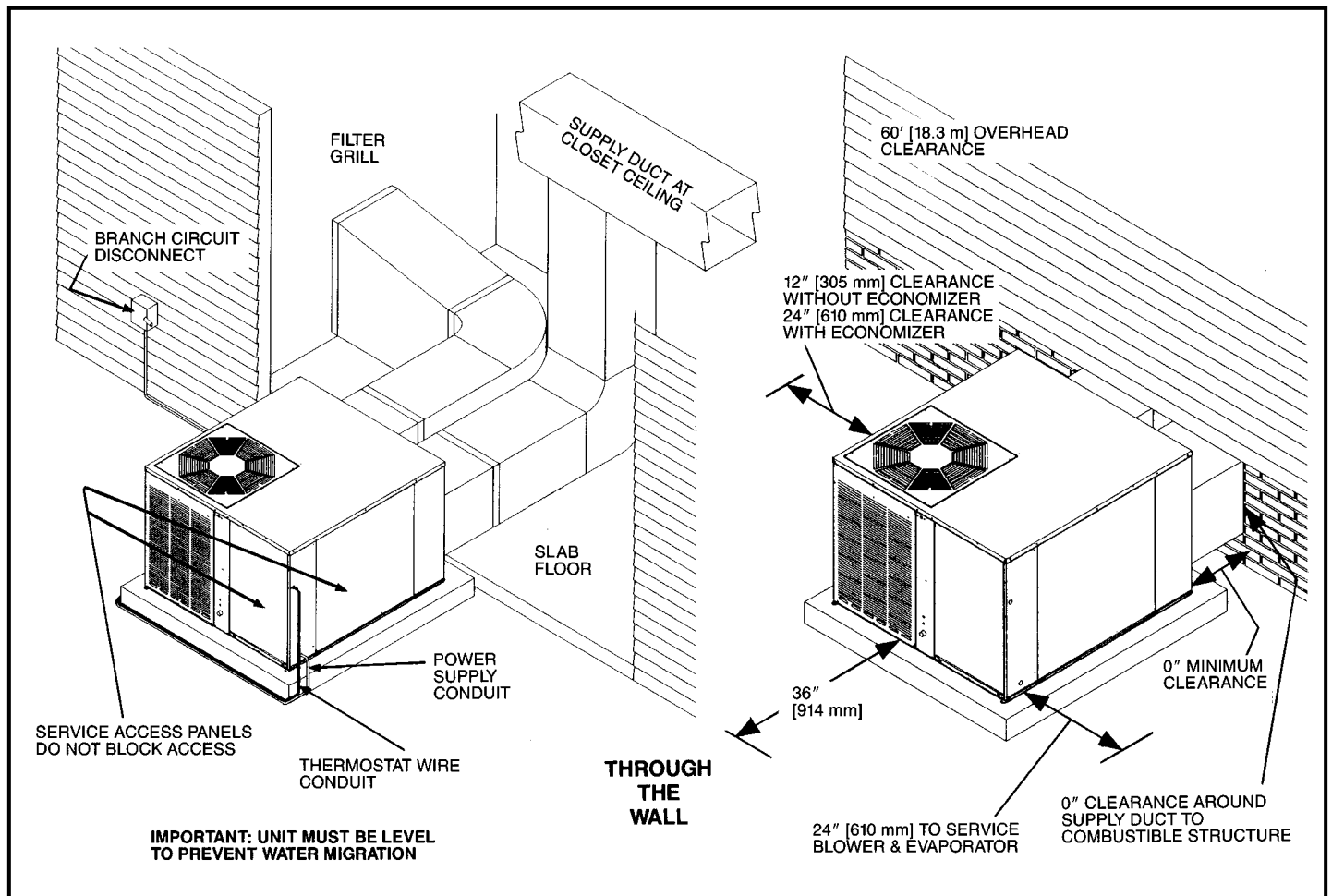

AUXILIARY ELECTRIC HEATER KITS CHARACTERISTICS AND APPLICATION

208/240 Volt, Single Phase, 60 HZ									
Nominal Size Tons [kW]	Unit Kit Nominal kW	No. of Elements	No. of Sequence Steps	Rated Heater kW @ 208/240 V	Heater KBTU/Hr @ 208/240 V	Heater Amps. @ 208/240 V	Unit Min. Ckt. Ampacity @ 208/240 V	Overcurrent Protective Device Size	
								Min./Max. @ 208 V	Min./Max. @ 240 V
1.5 [5.28] 1-Phase	No Heat	—	—	—	—	—	14/14	20/20	20/20
	03	1	1	2.1/2.8	7.17/9.55	10.1/11.7	15/17	20/20	20/20
	05	1	1	3.6/4.8	12.28/16.38	17.3/20.0	24/27	25/25	30/30
	06	2	1	4.2/5.6	14.33/19.11	20.2/23.3	27/31	30/30	35/35
2.0 [7.03] 1-Phase	08	2	1	5.7/7.6	19.45/25.93	27.4/31.6	36/42	40/40	45/45
	No Heat	—	—	—	—	—	17/17	25/25	25/25
	03	1	1	2.1/2.8	7.17/9.55	10.1/11.7	17/17	25/25	25/25
	05	1	1	3.6/4.8	12.28/16.38	17.3/20.0	24/27	25/25	30/30
	06	2	1	4.2/5.6	14.33/19.11	20.2/23.3	27/31	30/30	35/35
2.5 [8.79] 1-Phase	08	2	1	5.7/7.6	19.45/25.93	27.4/31.6	36/42	40/40	45/45
	10	2	1	7.2/9.6	24.57/32.76	34.6/40.0	45/52	45/45	60/60
	No Heat	—	—	—	—	—	21/21	25/30	25/30
	03	1	1	2.1/2.8	7.17/9.55	10.1/11.7	23/23	25/30	25/30
	05	1	1	3.6/4.8	12.28/16.38	17.3/20.0	25/28	25/30	30/30
3.0 [10.55] 1-Phase	06	2	1	4.2/5.6	14.33/19.11	20.2/23.3	28/32	30/40	35/40
	08	2	1	5.7/7.6	19.45/25.93	27.4/31.6	37/43	40/40	45/45
	10	2	1	7.2/9.6	24.57/32.76	34.6/40.0	46/53	50/50	60/60
	15	3	1	10.8/14.4	36.85/49.13	51.9/60.0	68/78	70/70	80/80
	No Heat	—	—	—	—	—	17/17	20/25	20/25
3.0 [10.55] 3-Phase	10	3	1	7.2/9.6	24.57/32.76	20.0/23.1	28/32	30/30	35/35
	12	3	1	8.6/11.4	29.34/38.90	23.8/27.4	33/38	35/35	40/40
	15	3	1	10.8/14.4	36.85/49.13	30.1/34.7	41/47	45/45	50/50
3.5 [12.31] 1-Phase	No Heat	—	—	—	—	—	27/27	35/40	35/40
	06	2	1	4.2/5.6	14.33/19.11	20.2/23.3	28/32	35/40	35/40
	08	2	1	5.7/7.6	19.45/25.93	27.4/31.6	37/43	40/40	45/45
	10	2	1	7.2/9.6	24.57/32.76	34.6/40.0	46/53	50/50	60/60
	15	3	1	10.8/14.4	36.85/49.13	51.9/60.0	68/78	70/70	80/80
3.5 [12.31] 3-Phase	No Heat	—	—	—	—	—	20/20	25/30	25/30
	10	3	1	7.2/9.6	24.57/32.76	20.0/23.1	28/32	30/30	35/35
	12	3	1	8.6/11.4	29.34/38.90	23.8/27.4	33/38	35/35	40/40
	15	3	1	10.8/14.4	36.85/49.13	30.1/34.7	41/47	45/45	50/50
4.0 [14.07] 1-Phase	No Heat	—	—	—	—	—	36/36	45/50	45/50
	06	2	1	4.2/5.6	14.33/19.11	20.2/23.3	36/36	45/50	45/50
	08	2	1	5.7/7.6	19.45/25.93	27.4/31.6	40/45	45/50	45/50
	10	2	1	7.2/9.6	24.57/32.76	34.6/40.0	49/56	50/50	60/60
	15	3	1	10.8/14.4	36.85/49.13	51.9/60.0	71/81	80/80	90/90
4.0 [14.07] 3-Phase	No Heat	—	—	—	—	—	23/23	30/35	30/35
	10	3	1	7.2/9.6	24.57/32.76	20.0/23.1	31/35	35/35	35/35
	12	3	1	8.6/11.4	29.34/38.90	23.8/27.4	36/40	40/40	40/40
	15	3	1	10.8/14.4	36.85/49.13	30.1/34.7	44/49	45/45	50/50

Copper Wire Size—AWG (1% Voltage Drop)

SUPPLY WIRE LENGTH-Feet	CIRCUIT AMPACITY																							
	15	20	25	30	35	40	45	50	55	60	65	70	75	80	85	90	95	100	105	110	115	120	125	
300	4	3	2	2	1	1/0	1/0	2/0	2/0	3/0	3/0	3/0	4/0	4/0	4/0	4/0	250	250	250	250	300	300	300	
250	4	4	3	3	2	1	1	1/0	1/0	2/0	2/0	2/0	3/0	3/0	3/0	4/0	4/0	4/0	4/0	4/0	250	250	250	
200	6	4	4	4	3	2	2	1	1	1/0	1/0	1/0	2/0	2/0	2/0	3/0	3/0	3/0	3/0	3/0	4/0	4/0	4/0	
150	8	6	6	4	4	4	3	3	2	2	1	1	1/0	1/0	1/0	2/0	2/0	2/0	2/0	2/0	2/0	3/0	3/0	
100	10	8	8	6	6	6	4	4	4	3	3	2	2	2	1	1	1	1	1	1/0	1/0	1/0	1/0	
50	14	12	10	10	8	8	6	6	6	4	4	4	3	3	3	2	2	2	2	2	1	1	1	

Notes: 1. Wire size based on 60°C. type copper conductors below 100 ampacity. 2. Wire size based on 75°C. type copper conductors for 100 ampacity and above.

NOTES

Before proceeding with installation, refer to installation instructions packaged with each model, as well as complying with all Federal, State, Provincial, and Local codes, regulations, and practices.

**RHEEM
AIR CONDITIONING
DIVISION**

5600 Old Greenwood Road, Fort Smith, Arkansas 72903



"In keeping with its policy of continuous progress and product improvement, Rheem reserves the right to make changes without notice."